



Mercer Island Mixed-Use

2885 78th Avenue Southeast
Mercer Island, WA

Drainage Report

September 2021



Drainage Report

September 2021

Prepared for:

Johnston Architects, PLLC
100 Northeast Northlake Way, Suite 200
Seattle, WA 98105

Prepared by:

Winnie Lai, PE
Joe Eberhardt, PE
KPF Consulting Engineers
1601 Fifth Avenue, Suite 1600
Seattle, WA 98101
(206) 622-5822
KPF Project No. 1800596

This page intentionally left blank.

Table of Contents

1. Project Overview	1
Civil-Related Permits Required	2
2. Existing Condition Summary	2
Subsurface Investigation	2
3. Offsite Analysis	3
Qualitative Analysis	3
Upstream	3
Downstream	3
4. Permanent Stormwater Control Plan	4
Section 1 – Threshold Discharge Areas.....	4
Section 2 – Existing Site Hydrology	4
Section 3 – Developed Site Hydrology.....	4
Section 4 – Performance Goals and Standards.....	4
Section 5 – Onsite Stormwater Management	5
Section 6 – Flow Control System	5
Section 7 – Runoff Treatment	6
Section 8 – Conveyance System Analysis and Design	6
5. Minimum Requirements	6
Minimum Requirement No. 1: Preparation of a Stormwater Site Plan.....	6
Minimum Requirement No. 2: Construction Stormwater Pollution Prevention	6
Minimum Requirement No. 3: Source Control of Pollution	7
Minimum Requirement No. 4: Preservation of Natural Drainage Systems and Outfalls.....	7
Minimum Requirement No. 5: Onsite Stormwater Management	7
Minimum Requirement No. 6: Runoff Treatment	7
Minimum Requirement No. 7: Flow Control	7
Minimum Requirement No. 8: Wetlands Protection	7
Minimum Requirement No. 9: Operations and Maintenance	8

List of Figures

Figure 1-1: Vicinity Map (image courtesy of Google).....	1
--	---

List of Tables

Table 4-1: Sub-Basin Areas	5
----------------------------------	---

Appendices

Appendix A – Geotechnical Report

Appendix B – Infiltration Feasibility Map

Appendix C – Offsite Drainage Basin Maps

Appendix D – Project Site Drainage Basin Map

Appendix E – Minimum Requirements Flow Charts

Appendix F – MGSFlood Report

Appendix G – Conveyance Calculations

Appendix H – Operations and Maintenance Manual

Appendix I – CDM Smith Contaminated Soils Analysis

1. Project Overview

The project site is located at 2750 77th Avenue Southeast and 2885 78th Avenue Southeast in Mercer Island, Washington, Tax Parcel No. 5315101316 and 5315101326 (see Figure 1-1). The project site includes the 0.46-acre and 1.00-acre parcels, as well as 0.20 acres of improvements in the adjacent rights-of-way. The project site is located in Mercer Island Basin 10 of the Cedar River Watershed, and is bounded by 78th Avenue Southeast to the east, Southeast 29th Street to the south, 77th Avenue Southeast to the west, McDonald's to the north, and First Church of Christ, Scientist to the southwest.

The existing site consists of two parcels, which consist of retail buildings, a parking lot, and planting beds. All existing onsite improvements will be removed and landscaping will be cleared for the proposed development. The adjacent rights-of-way are currently developed with paved roadway, curb, sidewalks, driveways, and landscaping. The existing roadways along all frontages and the curb along the 77th Avenue Southeast frontage, except for pavement and curb restoration for utility connections, the curb cut for the new driveway entrance, and the parking pull-outs on 78th Avenue Southeast, are to remain.

The proposed development will consist of two townhouses and a four-story, mixed-use residential building with two levels of below-grade parking. Onsite improvements will consist of a through-block connection at the north end of the site, a residential amenity space and courtyard area, a south plaza area, hardscaping for pedestrian pathways, and landscaping. Offsite improvements will consist of new sidewalk, curb, two driveway entrances, landscaping, street trees, street lights, new parking pull-outs on 78th Avenue Southeast, a new curb bulb and curb ramp at the intersection of 78th Avenue Southeast and Southeast 29th Street, and utility connections to serve the building.



Figure 1-1: Vicinity Map (image courtesy of Google)

This Drainage Report is prepared in conjunction with the Civil Plan Set, as part of the project's Stormwater Site Plan. A Stormwater Site Plan is a comprehensive report and drawing set containing the technical information and analysis necessary for regulatory agencies to evaluate the proposed improvements for compliance with the stormwater requirements set forth by the Mercer Island City Code Section 15.19050 (Standards for New and Development and Redevelopment) and the Department of Ecology's 2014 Stormwater Management Manual for Western Washington (SWMMWW).

CIVIL-RELATED PERMITS REQUIRED

City of Mercer Island:

- Building Permit

Other Permits from Other Agencies:

- Notice of Intent for coverage under the Department of Ecology Construction Stormwater General Permit

Contractor-related permits and non-civil-related permits are not listed here.

2. Existing Condition Summary

The project site drains to the public storm system, which ultimately discharges to Lake Washington. The existing site generally slopes from east to west, with approximately 10 feet of elevation change. Low levels of contaminants are found in the soils on the southern portion of the site, where a dry cleaning business once operated. There is a gas station located south of the project site, which may be a potential offsite source of contamination. See Appendix I for an assessment of contaminated soils onsite, prepared by CDM Smith, dated June 2018. The assessment concluded that the project site is not considered a Model Toxics Control Act (MTCA) site and the only cleanup required would be special handling during excavation and disposal.

Per City of Mercer Island GIS, the project site is located in a potential landslide and seismic hazard area. Per the Geotechnical Report completed for the project by Hart Crowser, Inc., dated May 1, 2015, the risk of seismic hazards and slope failure for the project is low. A copy of the report is included for reference in Appendix A. There are no other known critical areas, such as high erosion risk, wetlands, or streams, located within or adjacent to the project site. There are no known groundwater wells or septic systems on the project site or within 100 feet of the project site. The project site is not located in an aquifer recharge area, wellhead protection area, or 100-year flood zone. There are no known historical drainage problems or areas of high potential for erosion and sediment deposition onsite.

SUBSURFACE INVESTIGATION

A subsurface investigation was completed for the project by Hart Crowser, Inc. to characterize subsurface conditions for the project site; see the Geotechnical Report in Appendix A. In general, the investigation revealed fill at depths varying between approximately 2 to 20 feet over impermeable glacial silt and clay.

Groundwater was encountered at depths of 5 feet to 25 feet. Per the subsurface investigation, the recommended design groundwater table elevation is 75 feet.

Per the Mercer Island Low Impact Development (LID) Infiltration Feasibility Map, onsite soils are not suitable for infiltrating LID facilities. A copy of the map has been included for reference in Appendix B.

3. Offsite Analysis

A qualitative analysis has been performed for 1/4 mile downstream of the project site. Refer to Appendix C for Offsite Drainage Basin Maps that show the downstream conveyance system, 1/4-mile downstream point, and the ultimate discharge location to Lake Washington.

QUALITATIVE ANALYSIS

Available plans, studies, and maps pertaining to the offsite study area have been reviewed. No problems were observed to be reported during the resource review that will be impacted by runoff from development of the project site.

A site inspection of the system was conducted on November 1, 2020, to verify surface conditions of the site and the downstream storm conveyance system. Surface conditions of the downstream storm conveyance system were observed to be consistent with available plans and maps. The weather was sunny and it was not raining.

UPSTREAM

There are no upstream areas draining onto the project site. Upstream areas in the rights-of-way are collected with existing drainage structures, and do not drain onto the project site.

DOWNSTREAM

Offsite runoff along the project frontage drains to the existing 8-inch storm main in 78th Avenue Southeast, the existing 24-inch storm main in Southeast 29th Street, and the existing 42-inch storm main in 77th Avenue Southeast. In existing conditions, onsite runoff is collected by the onsite storm conveyance system and discharges to either the storm main on Southeast 29th Street or the storm main on 77th Avenue Southeast. All runoff from the site converges in the 42-inch storm main.

The point of compliance of the project site, at 1/4 mile downstream, is the existing 60-inch WSDOT trunk main located in the eastbound lane of I-90. The contributing area to the 60-inch WSDOT trunk main is approximately 226 acres. The trunk main drains north and discharges to an existing stream. The stream discharges to a piped stream, which discharges to Lake Washington, approximately 0.6 mile downstream of the project site. Refer to Appendix C for Offsite Drainage Basin Maps.

There are no streams, wetlands, reported upland erosion impacts, or potential significant destruction of aquatic habitats on the project site or within the storm conveyance system up to 1/4 mile downstream of the site. As discussed in Chapter 2, the risk of slope failure for the project is low. No existing or potential constrictions, capacity deficiencies, or flooding problems were identified during the resource review and site inspection.

The project will reduce the peak flows from the project site to match forested conditions for 50 percent of the 2-year storm up to the full 50-year storm. Therefore, the project is not anticipated to create new or aggravate existing downstream drainage issues. See Chapter 4, Sections 2 and 6 for further discussion.

4. Permanent Stormwater Control Plan

SECTION 1 – THRESHOLD DISCHARGE AREAS

The project site is treated as a single Threshold Discharge Area (TDA), since runoff from the project site is contained in a single basin at the 1/4-mile point in the downstream stormwater conveyance system. The TDA is approximately 1.66 acres, including the 0.46-acre and 1.0-acre parcels and the 0.20 acres in the rights-of-way. Refer to the Project Site Drainage Basin Map in Appendix D for extents and surface coverage of the TDA and project site.

SECTION 2 – EXISTING SITE HYDROLOGY

Stormwater runoff flow patterns for the existing project site are described in Chapter 2 of this report.

As described in the geotechnical report, till soils are present below surficial soils on the project site. Therefore, till soils are used to model both the existing and proposed hydrologic conditions of landscape areas of the site. Per Section I-2.5.7 of the SWMMWW, forested cover shall be used for the pre-developed condition.

See Appendix F for the MGSFlood Report, which includes information about hydrologic inputs and calculated flows for the existing project site.

SECTION 3 – DEVELOPED SITE HYDROLOGY

Runoff from the proposed condition of the project site will continue to drain to the public storm system in the right-of-way, generally matching existing drainage patterns.

Onsite runoff will be collected in a new private stormwater conveyance system and directed to the proposed stormwater detention vault located below level P1 of the proposed building. **The discharge pipe from the detention vault will be pumped to a proposed catch basin at the southwest corner of the site, which will connect to the existing catch basin in the sidewalk on Southeast 29th Street. The existing catch basin discharges to the 24-inch storm main on Southeast 29th Street. The sidewalk and landscaping areas in the rights-of-way are infeasible to collect and convey to the stormwater detention vault. These areas will sheet flow to the curb and gutter and will be conveyed in the City's public storm system. The stormwater detention vault will over-detain the onsite flows to account for the offsite areas that are infeasible to collect and convey to the stormwater detention vault. All runoff from the site converges in the 42-inch trunk main on 77th Avenue Southeast, which ultimately discharges to Lake Washington.**

See Appendix F for the MGSFlood Report, which includes information about hydrologic inputs and calculated flows for the proposed project site.

SECTION 4 – PERFORMANCE GOALS AND STANDARDS

Per Figure I-2.4.1 of the SWMMWW, the project is determined to be redevelopment because the site has more than 35 percent of existing impervious coverage. Per Table I-2.5.1 of the SWMMWW, redevelopment projects that are inside the Urban Growth Area on a parcel less than 5 acres shall employ feasible best management practices (BMPs) listed in List No. 2 in Section I-2.5.5 of the SWMMWW.

Per Section I-2.5.6 of the SWMMWW, water quality treatment is not required for this project because the site improvements will create less than 5,000 square feet of Pollution-Generating Hard Surface (PGHS).

Per Section I-2.5.7 of the SWMMWW, flow control is required for this project because the site improvements will result in more than 10,000 square feet of impervious surface and the project discharges to a stream before outfalling to Lake Washington. The post-developed discharge peak flows and durations shall match the forested land cover discharge rates from 50 percent of the 2-year peak flow up to the full 50-year peak flow.

Refer to the applicable minimum requirement flow charts in Appendix E. Refer to subsequent sections in this chapter for additional information.

SECTION 5 – ONSITE STORMWATER MANAGEMENT

BMPs listed in Section I-2.5.5 of the SWMMWW were evaluated for new and replaced hard surfaces and converted vegetation areas for the project.

All disturbed lawn and landscape areas will be amended per the requirements of BMP T5.13 – Post-Construction Soil Quality and Depth.

As discussed in Chapter 2, onsite soils are not suitable for infiltrating LID facilities. Therefore, infiltrating BMPs, including BMP T5.10A – Downspout Full Infiltration, BMP T7.30 – Infiltrating Bioretention, BMP T5.10C – Perforated Stub-Out Connections, and BMP T5.15 – Permeable Pavements are infeasible for all surfaces.

BMP T5.30 – Full Dispersion, BMP T5.10B – Downspout Dispersions Systems, BMP T5.12 – Sheet Flow Dispersion, and BMP T5.11 – Concentrated Flow Dispersion are infeasible because the minimum vegetated flow path and setback requirements cannot be met.

Per MICC Section 15.09.050.A.2, if all OSM BMPs are considered infeasible for roofs and hard surfaces, onsite detention shall be evaluated. A detention vault is proposed to meet Minimum Requirement No. 7, and will also meet OSM requirements.

SECTION 6 – FLOW CONTROL SYSTEM

An underground stormwater detention vault is proposed to meet the applicable flow control standards. The detention vault has been sized for the entire project area. Runoff from onsite areas will be directed to the detention vault via private stormwater conveyance system. The detention vault will over-detain the onsite flow rate to account for offsite areas that are infeasible to collect and convey to the detention vault. **The building will be waterproofed to grade. Therefore there will be no permanent groundwater discharge directed to the detention vault.**

The detention vault was sized using MGSFlood, a continuous runoff model approved by the Department of Ecology. Break down of hard surface and vegetated areas are shown in Table 4-1 below.

Table 4-1: Sub-Basin Areas

	VEGETATION (FORESTED)	VEGETATION AT GRADE (TILL)	VEGETATION ON STRUCTURE (GREEN ROOF)	HARD SURFACE	TOTAL SITE AREA
PRE-DEVELOPED AREAS	72,306 SF (1.66 AC)	-	-	-	72,306 SF (1.660 AC)
POST-DEVELOPED AREAS	-	3,430 SF (0.079 AC)	6,169 SF (0.142 AC)	62,707 SF (1.439 AC)	72,306 SF (1.660 AC)

The detention vault dimensions are 45.77 feet by 112.46 feet, with 7.5-foot depth of storage. The total area of the detention vault is 5,073 square feet, which excludes the area of any structural columns and walls inside the vault. The detention vault consists of 38,048 cubic feet of storage volume, which is consistent with the volume at riser crest in the MGS Flood model. A control structure is provided on the outflow pipe from the detention vault to meet the flow control standard. The detention vault is designed in accordance with Section III-3.2.3 of the SWMMWW. Refer to Appendix D for Project Site Drainage Basin Map showing areas draining to the detention vault and Appendix F for the MGSFlood Report showing flow duration performance.

SECTION 7 – RUNOFF TREATMENT

PGHS for this project include the service lane, the loading zone, and driveway entrance off 77th Avenue Southeast, the driveway entrance off Southeast 29th Street, and the parking pull-outs on 78th Avenue Southeast. The total PGHS is 3,490 square feet. Since the project will create less than 5,000 square feet of PGHS, this project is not subject to water quality requirements as described in Chapter 4, Section 4 of this report.

SECTION 8 – CONVEYANCE SYSTEM ANALYSIS AND DESIGN

The existing public storm drain system was not analyzed for conveyance because the project will not be increasing the peak flow rates.

Storm drain conveyance calculations, using Manning's equation, have been performed to demonstrate that the private storm drain system is sized to handle flows up to the 100-year storm event. See Appendix G for conveyance calculations. The full flow capacity of the 12-inch detention vault discharge pipe is 6.55 cubic feet per second. Per the MGSFlood Report in Appendix F, the 100-year post-development peak flow rate from the detention vault is 0.09 cubic feet per second. Therefore, the detention vault discharge pipe is adequately sized to convey the 100-year peak flow from the site.

5. Minimum Requirements

As discussed in Chapter 4, Section 4 of this report, this is a Redevelopment Project, and Minimum Requirement Nos. 1-9 apply to the project. A summary of how the project meets each minimum requirement is included below. As discussed in Chapter 4, Section 1 of this report, this project consists of only one TDA, and therefore all applicable Minimum Requirements will be addressed over the entire project limits.

MINIMUM REQUIREMENT NO. 1: PREPARATION OF A STORMWATER SITE PLAN

This drainage report accompanies the Civil Plan Set. The report and plans document temporary and permanent stormwater controls and satisfies the requirements for Stormwater Site Plan preparation per the SWMMWW.

MINIMUM REQUIREMENT NO. 2: CONSTRUCTION STORMWATER POLLUTION PREVENTION

A Construction Stormwater Pollution Prevention Plan (SWPPP) addressing the 13 elements has been prepared for this site as required by Minimum Requirement No. 2 and the Washington State Department of Ecology Construction Stormwater General permit. The project's general contractor will be required to update the SWPPP, as needed, to meet onsite conditions and phasing of construction. The Washington State

Department of Ecology will regulate and enforce the necessary Construction Stormwater General Permit requirements.

MINIMUM REQUIREMENT NO. 3: SOURCE CONTROL OF POLLUTION

Relevant source control BMPs are implemented to prevent stormwater from coming in contact with pollutants. [See SWPPP for additional information on how source control of pollution will be implemented.](#) The following typical source control BMPs for this type of project have been selected from the SWMMWW and are listed below:

- BMP C103: High Visibility Fence
- BMP C105: Stabilized Construction Entrance
- BMP C120: Temporary and Permanent Seeding
- BMP C121: Mulching
- BMP C123: Plastic Covering
- BMP C140: Dust Control
- BMP C151: Concrete Handling
- BMP C152: Sawcutting and Surfacing Pollution Prevention

MINIMUM REQUIREMENT NO. 4: PRESERVATION OF NATURAL DRAINAGE SYSTEMS AND OUTFALLS

The site was previously developed to collect and discharge stormwater to the City-owned stormwater system. The proposed development will continue to collect and discharge stormwater to the same system.

MINIMUM REQUIREMENT NO. 5: ONSITE STORMWATER MANAGEMENT

Onsite Stormwater Management BMPs are required to be evaluated for this project. See Chapter 4, Sections 4 and 5 of this report for further discussion.

MINIMUM REQUIREMENT NO. 6: RUNOFF TREATMENT

Runoff treatment is not required for this project. See Chapter 4, Sections 4 and 7 of this report for further discussion.

MINIMUM REQUIREMENT NO. 7: FLOW CONTROL

Flow control is provided meeting the requirements set forth in the SWMMWW. See Chapter 4, Sections 4 and 6 of this report for further discussion.

MINIMUM REQUIREMENT NO. 8: WETLANDS PROTECTION

This site does not directly or indirectly discharge into a wetland. Therefore, this requirement does not apply to this project.

MINIMUM REQUIREMENT NO. 9: OPERATIONS AND MAINTENANCE

An Operations and Maintenance Manual for the onsite stormwater collection and conveyance infrastructure is included in Appendix H.

Appendix A

Geotechnical Report

This page intentionally left blank.



Geotechnical Engineering Design Report
Mercer Island Multi-Family
Development
Seattle, Washington

Prepared for
Hines

May 1, 2015
17984-01

Geotechnical Engineering Design Report

Mercer Island Multi-Family Development

Mercer Island, Washington

Prepared for

Hines

May 1, 2015

17984-01

Prepared by

Hart Crowser, Inc.



Matthew W. Veenstra, PE
Geotechnical Engineer



May 1, 2015

David G. Winter, PE
Vice President

Contents

PROJECT UNDERSTANDING	1
SITE CONDITIONS	1
FIELD EXPLORATIONS	2
SOIL CONDITIONS	2
GROUNDWATER CONDITIONS	3
GEOTECHNICAL ENGINEERING CONCLUSIONS AND RECOMMENDATIONS	3
Earthquake Engineering	3
Seismic Setting	3
Seismic Hazards	4
Building Code Seismic Parameters	4
Excavation and Shoring	4
Lateral Soil Pressures for Design of Temporary Shoring Walls	5
Surcharge Pressures on Shoring	6
Soldier Pile Design	6
Lagging Design	6
Tieback Design	7
Permanent Subgrade Wall Design	8
Earth Pressures	8
Hydrostatic Groundwater Pressure	9
Seismic Earth Pressure on Walls	9
Surcharge Pressures on Walls	9
Foundation Design Recommendations	9
GROUNDWATER CONTROL	10
Slug Results	10
Temporary Construction Dewatering	10
Permanent Drainage	10
Walls Placed Against Shoring	11
Slabs-on-Grade	11
Backfilled Walls	11
Final Site Drainage	12
Pavement Areas	12
GEOTECHNICAL RECOMMENDATIONS FOR CONSTRUCTION	12

Soldier Pile Installation	12
Lagging Installation	13
Tieback Installation	13
Shoring Monitoring Program	16
Foundation Construction	17
Earthwork	18
Site Preparation and Grading	18
Structural Fill	18
Use of On-Site Soil as Structural Fill	19
Temporary Cuts	19

RECOMMENDATIONS FOR CONTINUING GEOTECHNICAL SERVICES	20
---	-----------

REFERENCES	20
-------------------	-----------

TABLES

1	2012 IBC Seismic Design Parameters	4
2	Axial Capacity Parameters for Drilled Soldier Piles	6
3	Recommended Temporary Lagging Thickness	7
4	Tentative Pullout Resistance for Tiebacks with Pressure-Grouted Bond Zone	7
5	Soil Equivalent Fluid Unit Weights for Walls Backfilled with Structural Fill	9

FIGURES

1	Vicinity Map
2	Site and Exploration Plan
3	Generalized Subsurface Cross Section A-A'
4	Generalized Subsurface Cross Section B-B'
5	Generalized Subsurface Cross Section C-C'
6	Generalized Subsurface Cross Section D-D'
7	Lateral Earth Pressures Temporary Shoring
8	Surcharge Pressures Determination of Lateral Pressure Acting on Adjacent Shoring
9	Lateral Pressures for Permanent Walls Constructed Against Shoring
10	Elevation of Top of Competent Soils

ATTACHMENT 1

Slug Test Results

APPENDIX A

Field Exploration Methods and Analysis

APPENDIX B

Historical Explorations

Geotechnical Report

Mercer Island Multi-Family Development

Mercer Island, Washington

This report provides our geotechnical engineering recommendations for the Mercer Island Multi-Family Development in Mercer Island, Washington.

Our scope of work included:

- Collecting and assessing subsurface conditions from historical explorations;
- Drilling four borings;
- Installing monitoring wells in two of the borings;
- Conducting one dynamic cone penetration test in the northwest corner of the site;
- Preparing logs of the soil explorations;
- Assessing groundwater conditions including slug testing of new and existing wells;
- Conducting engineering analysis; and
- Preparing this report summarizing our findings and presenting geotechnical recommendations.

We completed this work in general accordance with our contract dated October 15, 2014. This report is for the exclusive use of Hines and its design consultants for specific application to this project and site. We completed this work in accordance with generally accepted geotechnical engineering practices for the nature and conditions of the work completed in the same or similar localities, at the time the work was performed. We make no other warranty, express or implied.

PROJECT UNDERSTANDING

The project consists of a five-story, mixed-use building with one to two levels of below-grade parking. The proposed development site is shown on Figures 1 and 2.

We understand that the grading plan is for a basement finish floor elevation of 63 feet with a ramp up to elevation 72 feet in the northwest corner of the site. The existing ground surface generally slopes from about elevation 90 feet along 78th Avenue SE to about elevation 82 feet along 77th Avenue SE. The bottom of the excavation is expected to be about 22 to 32 feet below existing ground surface.

In this report, the elevation datum is NAVD 88 and the horizontal datum is NAD 83/91. Length and distance units are in U.S. feet unless otherwise noted.

SITE CONDITIONS

We visited the site on September 29, 2013, to observe the condition of the on-site buildings, nearby buildings, and paved surfaces. The buildings did not show signs of excessive building settlement such as large cracks in the walls or sloping lines. We did observe concrete cracking on the exterior stairway on the north side of the 2885 78th Avenue SE building that houses the Seven Star restaurant and a slight separation of concrete masonry unit (CMU) joints on the southwest corner of the 2864 77th

Avenue SE building that houses Terra Bella; however, these observed conditions are not definitively caused by foundation settlement.

According to property records accessed on the City of Mercer Island website, it appears that most of the buildings on or near the site are founded on spread foundations. However, the McDonald's restaurant immediately north of the site and the building immediately north of the McDonald's (2737 78th Avenue SE) were both constructed using timber pile foundations up to 25 feet long, which indicates unsuitable soils in the vicinity.

FIELD EXPLORATIONS

Exploration locations by Hart Crowser for the current project are shown on Figure 2 and exploration logs are provided in Appendix A. We also observed push probes conducted by Farralon Consulting and made our own exploration logs for those explorations. We also reviewed geotechnical reports by Terra Associates, Inc. (Terra 2012) and ABPB Consulting (ABPB 2012). The locations of historical explorations and Farralon's push probes are provided on Figure 2 and the logs are provided in Appendix B.

On November 12 to 13, 2014, we performed a subsurface investigation including four hollow-stem auger borings, HC-1 to HC-4, from 36.5 to 41.5 feet below ground surface (bgs) and one dynamic cone penetrometer, HC-5, to 20.5 feet bgs. We installed monitoring wells in borings HC-1 and HC-2. On November 14, 2014, we developed the monitoring wells and on November 17, 2014, we performed slug testing on monitoring wells in borings HC-1, HC-2, APBP M3, and Terra B-1.

Our understanding of the subsurface conditions is based on current and historical explorations at the site. Subsurface conditions interpreted from explorations at discrete locations on the site and soil properties inferred from the field and laboratory tests formed the basis of the geotechnical recommendations in this report. The nature and extent of variations between explorations may not become evident until additional explorations are performed or construction begins. If variations are encountered, it may be necessary to reevaluate the recommendations made in this report. General soil and groundwater conditions are addressed below. Refer to exploration logs for more detailed information at specific locations.

SOIL CONDITIONS

The subsurface soil conditions are illustrated by generalized subsurface profiles AA' through DD' on Figures 3 through 6. Based on our interpretation of the borings, the regional topography, and our conversations with the current property owners, the site is likely a filled in swamp/marsh lowland area underlain by relatively impermeable glacial silt and clay.

As shown on the subsurface profiles, we have divided the lithology into four main soil units:

Unit 1. Loose to medium dense silty granular FILL, soft SILT, and PEAT. This unit is generally not suitable for conventional spread footings.

Unit 2. Medium stiff to hard SILT and silty CLAY. This unit is generally suitable for conventional spread footings with moderate bearing pressures but may require localized overexcavation and replacement with structural fill to provide adequate foundation subgrade.

Unit 3. Medium dense to dense SAND and silty SAND. This unit may be interbedded with Unit 2 and Unit 4 and is expected to be most prominent and most likely to be encountered along the southern end of the site. Excavations into this unit will likely require dewatering.

Unit 4. Hard SILT. This unit generally underlies the other soil units except along the southern end of the site. This unit is suitable for conventional spread footings with moderate to high bearing pressures.

In this report we define “competent soils” as Soil Units 2, 3 and 4.

GROUNDWATER CONDITIONS

Groundwater was observed during drilling at the site at depths of 5 to 25 feet. Groundwater occurs in the predominantly fine-grain soils (Units 1, 2, and 4) as perched water within discontinuous permeable lenses. Saturated groundwater conditions were observed in Unit 3. For design purposes, we recommend a groundwater table elevation of 75 feet.

GEOTECHNICAL ENGINEERING CONCLUSIONS AND RECOMMENDATIONS

Our recommendations are based on our current understanding of the project and the subsurface conditions interpreted from explorations at and near the site by Hart Crowser and others. If the nature or location of the facilities is different than we have assumed, we should be notified so we can review, change, and/or confirm our recommendations.

Earthquake Engineering

Seismic Setting

The seismicity of Western Washington is dominated by the Cascadia Subduction Zone (CSZ), where the offshore Juan de Fuca plate subducts beneath the continental North American plate. Three main types of earthquakes are typically associated with subduction zone environments: crustal, intraplate, and interplate earthquakes. Seismic records in the Puget Sound area clearly indicate a distinct shallow zone of crustal seismicity, the Seattle Fault, which may have surficial expressions and can extend to depths of 25 to 30 km. A deeper zone is associated with the subducting Juan de Fuca plate and produces intraplate earthquakes at depths of 40 to 70 km beneath the Puget Sound region (e.g., the 1949, 1965, and 2001 earthquakes) and interplate earthquakes at shallow depths near the Washington coast (e.g., the 1700 earthquake with an approximate magnitude of 9.0).

Seismic Hazards

- Based on our analysis and the planned depth of excavation, it is our opinion that the risk of liquefaction occurring across the site is low.
- The site is flat and there is no sloping ground near the site so the risk of lateral spreading or slope failure is low.
- The mapped northernmost splay of the Seattle Fault is about 0.5 miles south of the site. There is a remote potential for surface rupture at the site from a new splay of the Seattle Fault; however, this hazard is very low considering the Seattle Fault's 3,000-year recurrence interval, the many possible locations for surface rupture, and the chance that the fault would not produce surface rupture in this segment of the fault.

Building Code Seismic Parameters

Table 1 provides 2012 International Building Code (IBC) seismic design parameters for the site latitude and longitude and the soil Site Class. The parameters were obtained from the USGS US Seismic Design Maps web application (<http://earthquake.usgs.gov/designmaps/us/application.php>) accessed on December 9, 2014.

Based on the soil conditions across the site, it is our opinion that the site is best characterized as site class D.

Table 1 – 2012 IBC Seismic Design Parameters

Parameter	Value
Latitude	47.58485
Longitude	122.23438
Site Class	D
PGA	0.568
S _s	1.380
S ₁	0.531
F _a	1.0
F _v	1.5

Excavation and Shoring

We recommend a conventional shoring system of soldier piles, tiebacks, and wood lagging.

Our shoring recommendations assume that the excavation will extend down to at least the top of competent soils. Because the actual depth of competent soils may differ from our estimate, we recommend designing the shoring assuming the excavation extends an additional 2 feet below the planned bottom of excavation to allow for potential over-excavation along the shoring wall if needed.

At the ramp in the northwest corner, the shoring should be designed assuming the existing ramp subgrade soils will be excavated down to competent soils, the same as for the rest of the site.

Perched groundwater will likely be encountered in sand zones throughout the excavation depth. Excavations into Soil Unit 3, sandy soils, will likely require active dewatering.

Shoring should be designed by a professional structural engineer registered in the State of Washington. We also recommend that we be given the opportunity to review the geotechnical aspects of the shoring design before construction. It is generally not the purpose of this report to provide specific criteria for the contractor's construction means and methods. It should be the responsibility of the shoring contractor to verify actual ground conditions and determine the construction methods and procedures needed to install an appropriate shoring system.

Lateral Soil Pressures for Design of Temporary Shoring Walls

Lateral earth pressures for the shoring design depend on the type of shoring and its ability to deform. If the top of the shoring is allowed to deform on the order of 0.001 to 0.002 times the shoring height, and if no settlement-sensitive structures or utilities are within the zone of deformation, the shoring may be designed using active earth pressures. If settlement-sensitive structures or utilities exist within the potential zone of deformation, or where the shoring system is too stiff to allow sufficient lateral movement to develop an active condition, at-rest earth pressures should be used to design the shoring.

We expect that temporary shoring will consist of soldier piles and timber lagging with one or more levels of tiebacks. Tied-back or braced walls should be designed using a trapezoidal apparent earth pressure distribution. General earth pressure diagrams and recommendations for temporary shoring are provided on Figure 7.

The lateral earth pressures presented herein for soldier piles are based on non-sloping conditions behind the walls and drained conditions so that hydrostatic water pressure does not act on the walls above the base of the excavation. For design calculations, we recommend adding at least 2 feet to the proposed excavation depth to allow for possible surface pressures near the excavation (e.g., light vehicles, small material stockpiles).

Based on the assumed loading conditions and the applied loads, we expect the shoring system to deflect about 1 inch or less into the excavation. Individual soldier piles may deflect more than 1 inch or deflect away from the excavation.

Hart Crowser should review any soldier piles that deflect more than 1/2 inch to try to identify the cause of the deflection and to determine whether remedial measures are required.

Surcharge Pressures on Shoring

Additional lateral pressures due to surcharge loads (e.g., buildings, footings, heavy equipment, large material stockpiles) should be calculated using methods shown on Figure 8. These loads would be added to the loads calculated for the shoring walls. We recommend Hart Crowser review or complete the estimated surcharge loads when surcharge loads, footprints, and foundation plans of adjacent structures are available.

Soldier Pile Design

We recommend the following for soldier pile design:

- Soldier piles must be designed by a licensed structural engineer;
- Soldier piles should be designed for bending using a uniform loading equivalent to 80 percent of the design values and analyzed for shear using total load;
- To design against kickout, the lateral resistance should be computed using the passive pressure on Figure 7, acting over 2 times the diameter of the concreted shaft section or the pile spacing, whichever is less;
- The embedded portion of the pile shaft should be at least 2 feet in diameter; and
- Piles should be embedded at least 8 feet below the bottom of the excavation.

These recommendations assume proper installation of the soldier piles as discussed later in this report.

We recommend the allowable axial pile capacity parameters in Table 2 to calculate the vertical resistance of the soldier piles. The values assume that soldier piles are embedded into competent soils. The pile side friction above the bottom of the excavation should be neglected. The soldier piles should be embedded at least 10 feet below the base of the excavation.

Table 2 – Axial Capacity Parameters for Drilled Soldier Piles

Soil Unit	Allowable Unit Side Capacity	Allowable Unit End Capacity
Unit 1	0.5 ksf	NA
Units 2 – 4	2 ksf	10 ksf

Lagging Design

Temporary lagging should be designed in accordance with Federal Highway Administration (FHWA) Geotechnical Engineering Circular (GEC) 4 (FHWA 1999), structural engineering guidelines, soil type, and local experience. Table 3 provides recommended lagging thicknesses based on the FHWA recommendations.

Based on our site investigation, we recommend using a Soil Type of “Competent” for the eastern half of the site and “Difficult” for the western half of the site.

Table 3 – Recommended Temporary Lagging Thickness

		Clear Span of Lagging (feet)					
		5	6	7	8	9	10
		Minimum Actual Thickness of Rough Cut Timber Lagging (inches)					
Competent ^a	25 and under	2	3	3	3	4	4
	Over 25 to 60	3	3	3	4	4	5
Difficult ^a	25 and under	3	3	3	4	4	5
	Over 25 to 60	3	3	4	4	5	5
Potentially Dangerous ^a	15 and under	3	3	4	5	See note ^b	See note ^b
	Over 15 to 25	3	4	5	6	See note ^b	See note ^b
	Over 25	4	5	6	See note ^b	See Note ^b	See note ^b

Notes:

- Soil type as defined in WSDOT Standard Specifications section 6-16.3(6)A.
- For exposed wall heights exceeding the limits in Table 3, or where minimum rough-cut lagging thickness is not provided, the contractor should design the lagging in accordance with structural engineering guidelines and local experience. Soldier pile and lagging shoring may not be appropriate for these cases.

Tieback Design

We recommend the tentative allowable tieback pullout value in Table 4 for a typical 6-inch-diameter drilled hole with a pressure-grouted bond zone. The allowable transfer load includes a recommended factor of safety of 2.0. The factor of safety should be confirmed by completing at least two successful verification tests in each soil type. Additionally, each tieback should be proof-tested to 133 percent of the design load. Our recommended tieback testing program is included in Attachment 1. We recommend that the shoring contractor and/or designer determine a final design tieback pullout resistance based on their previous experience in Seattle, which must then be confirmed by field testing.

Table 4 – Tentative Pullout Resistance for Tiebacks with Pressure-Grouted Bond Zone

Soil Type	Allowable Transfer Load
Competent soils – Soil Units 2 through 4	2 kip/ft

We make the following additional recommendations for tieback design:

- Do not install the bond zone within Soil Unit 1 (fill, soft silt and clay, peat), if present.
- Tieback bond zones should be outside of the no-load zone. The no-load zone is shown on Figure 5 as a zone bounded by a 60-degree line to the horizontal that starts at a distance of $H/4$ from the bottom of the excavation, where H is the excavation height.
- Locate anchors at least three tieback diameters apart.
- Design anchor lengths so that they do not conflict with any underground support elements of adjacent structures.
- Identify existing facilities adjacent to the project site including buried utilities and foundations, as these may affect the location and length of the anchors.
- Allow the contractor to select the tieback anchor material and the installation technique. The shoring contractor should be contractually responsible for the design of the tieback anchors, as tieback capacity is largely a function of the means and methods of installation. The selected installation method must be confirmed using verification and proof-testing, as discussed in Attachment 1.
- Hart Crowser should review the design for anchor locations, capacities, and related criteria prior to implementation.

Permanent Subgrade Wall Design

This section and Figures 8 and 9 provide guidance for determining the permanent subgrade wall loads.

Earth Pressures

Permanent subsurface walls constructed adjacent to soldier pile shoring may be designed using the same earth pressure values and distribution that was used for shoring design. The earth pressure does not include surcharge loads such as loads from adjacent buildings; these must be calculated separately and added to get the total permanent lateral pressure.

Permanent walls that are backfilled and are not adjacent to shoring walls should be designed using a triangular earth pressure distribution. For typical granular fill soil, active and at-rest pressures may be determined using the equivalent fluid unit weights in Table 5. Note that the equivalent fluid density does not include any surface loading conditions or loading due to groundwater hydrostatic pressure; also, the ground surface behind the wall is assumed to be horizontal. Walls without drainage must be designed for full hydrostatic pressure.

The use of active and passive pressure is appropriate if the wall is allowed to yield a minimum of 0.001 times the wall height. For a non-yielding wall, at-rest pressures should be used.

Table 5 – Soil Equivalent Fluid Unit Weights for Walls Backfilled with Structural Fill

Soil Type	Parameter	Value (pcf)
Structural fill	Active earth pressure	35
	At-rest earth pressure	55
	Passive earth pressure ^a	300

Note:

a. Includes a factor of safety of 1.5.

Hydrostatic Groundwater Pressure

For walls permanently drained over the full height of the wall, hydrostatic groundwater pressure buildup is prevented and permanent wall design may neglect groundwater pressure. Hydrostatic uplift of the mat slab can be prevented by installing a drainage system beneath the mat slab.

For walls and floors that are not drained, a triangular lateral hydrostatic pressure of $62.4h_w$ psf should be added, where h_w is the depth of structure below the design groundwater level. The depth of the basement is expected to be above the regional groundwater table. However, perched groundwater will exert full hydrostatic pressure against the walls if they are not adequately drained. For undrained walls, we recommend a design water level of 5 feet bgs.

Seismic Earth Pressure on Walls

Lateral earth pressures based on the design earthquake for active and at-rest conditions can be assumed as uniform pressures in pounds per square foot of $8H$ and $12H$ (where H is the height of the wall in feet), respectively. The seismic earth pressure should be applied from the top of the wall to the bottom of the excavation, as shown on Figure 9. This seismic earth pressure is calculated using the 2012 IBC design hazard level for the site.

Surcharge Pressures on Walls

The pressures shown on Figures 7 and 9 do not include surcharge loads due to buildings, footings, heavy equipment, large stockpiles, and so forth. These loads must be calculated separately, using the methods shown on Figure 8 or similar, and added to the pressures determined using Figures 7 and 9.

We recommend Hart Crowser review or complete the estimated surcharge loads when surcharge loads, footprints, and foundation plans of adjacent structures are available.

Foundation Design Recommendations

We recommend using shallow spread footings bearing on competent soil. For shallow spread foundations bearing on competent soils we recommend an allowable bearing capacity of 3 kips per square foot (ksf). We expect less than 1 inch of post-construction settlement for foundations bearing on competent soils.

Figure 10 provides a contour map of the estimated elevation of the top of competent soils. The contours on Figure 10 are only an estimate and some amount of overexcavation and replacement with structural fill should be expected in order to reach competent soils. Also, any soil on site that is not firm and unyielding, or that is otherwise considered inadequate by Hart Crowser, will need to be over-excavated and replaced with structural fill or controlled density fill (CDF).

At the ramp location in the northwest corner of the site, we recommend over-excavating the ramp subgrade soils down to competent soil and then backfilling back up to ramp subgrade elevation with structural fill. The bottom of footings at the ramp location should be below the ramp backfill.

GROUNDWATER CONTROL

Slug Results

Water levels and slug testing results are presented in Attachment 1 and may be used for design of construction dewatering and estimating water flow into a permanent drainage system. Based on the slug test results we recommend average hydraulic conductivities for wells screened in Soil Unit 3, sand and silty sand, 9.0×10^{-5} to 8.3×10^{-4} centimeters per second (0.3 to 2.4 feet per day).

Temporary Construction Dewatering

Because construction will likely extend below the water table, temporary construction dewatering to maintain suitable working conditions in the excavation will be required. Water collected and discharged during construction will include surface water from precipitation and groundwater and may include process water from construction activities. For excavations to about elevation 70 feet, groundwater inflow is expected to be minimal and we expect that groundwater can be managed using trenches and sumps. For excavations deeper than elevation 70 feet, we recommend active dewatering during construction. We expect that the most efficient dewatering system will be a vacuum wellpoint system installed through the shoring system into saturated sands.

Our field testing and analysis results indicate that groundwater discharge during temporary construction dewatering could be on the order of 25 to 100 gallons per minute for an excavation to elevation 60 feet. Stormwater and process water are not included in this estimate and would generate additional water.

The amount of water discharged from the site depends on many factors including design and operation of the dewatering system (if applicable), the excavation depth and extent, and the variability in soil and groundwater properties. Rainfall, surface water, and groundwater from adjacent utility trenches can significantly increase short-term water discharge rates. Also, the time of year and nearby construction dewatering activities can affect groundwater flows.

Permanent Drainage

We modeled groundwater using the results of our field testing and the excavation footprint. Using the modeling results, we estimate that the average, long-term drainage rates for a subsurface drainage

system are on the order of 10 to 25 gallons per minute. Based on this low discharge rate, it should be feasible to construct the basement using permanent drainage. With a permanent subsurface drainage system, the structure does not have to be designed for hydrostatic groundwater pressure or as a “bathtub.” Limited waterproofing, such as bentonite panels, may be desirable at below-grade stairwells, elevator shafts, equipment rooms, and so forth to reduce seepage potential at the concrete joints. Additional recommendations for permanent drainage are provided below.

Walls Placed Against Shoring

Drainage board (e.g., Miradrain 6100) should be placed full coverage across the shoring wall below elevation 70 feet. Above elevation 70 feet, drainage panel coverage may be reduced to 2-foot-wide strips placed in between the soldier piles and up to the ground surface. The drainage board should be connected to a collector pipe and conveyed to a suitable discharge point.

Slabs-on-Grade

- Slab-on-grade floors should be underlain by a drainage layer consisting of at least 12 inches of free-draining material. We recommend mineral aggregate Type 21 or Type 22, City of Seattle Standard Specification 9-03.16, with the exception that this material should have less than 10 percent sand and less than 3 percent fines based on the minus-3/4 inch fraction.
- Drainage layer material should be submitted to Hart Crowser for gradation analysis and approval.
- Perimeter and cross drains should be placed at the bottom of the drainage layer.
- Cross drains should be spaced no more than 30 feet apart and perimeter drains should extend around the perimeter of the building. The cross drains and the perimeter drains should be tied together and sloped to drain to a suitable discharge point.
- A layer of polyethylene sheeting should be used to protect the drainage layer from concrete as the floor slab is poured.
- Drainage material should be compacted to 90 percent of maximum dry density as determined by the Modified Proctor Method, ASTM D 1557.

Backfilled Walls

Walls with soil backfilled on only one side will require drainage or they must be designed for full hydrostatic pressure. We recommend the following:

- Backfilling should be done with a minimum thickness of 18 inches of free-draining sand or sand and gravel that is well-graded (i.e., that has a wide range in particle size).
- Drains should be installed behind any backfilled subgrade walls. The drains, with cleanouts, should consist of perforated pipe a minimum of 4 inches in diameter placed on a bed of, and surrounded by, at least 6 inches of free-draining sand or sand and gravel. The drains should be sloped to carry the water to a sump or other suitable discharge.

- The backfill should be continuous and should envelop the drainage behind the wall.
- The drainage fill surrounding the pipe should be compatible with the size of the holes in the pipe.

Final Site Drainage

- The site should be graded in such a way that surface water will not pond near the structures.
- Roof drains should not be connected to the subgrade drainage system and should be sloped and tightlined to a suitable outlet away from the proposed building.

Pavement Areas

The pavement areas should be graded in such a way that surface water will not pond and will drain to a suitable outlet.

GEOTECHNICAL RECOMMENDATIONS FOR CONSTRUCTION

Soldier Pile Installation

- Installation methods should minimize caving soils or loosening of soil at the bottom of the drilled shaft which can reduce the bearing capacity in the zone of disturbed soil. Groundwater increases the chances of soil disturbance.
- Tieback de-tensioning and shoring failure could occur if bearing capacity is inadequate and soldier piles settle under the vertical component of the inclined tieback load. We recommend that a Hart Crowser representative closely monitor soldier pile installation for these conditions so construction methods can be adjusted accordingly.
- The contractor should be prepared to case the soldier pile holes where loose soils or groundwater seepage could cause loss of ground. Fill soils can be especially prone to caving and may require casing. The actual need for casing should be determined in the field at the time of installation.
- If the shaft excavation contains water or slurry, the contractor should tremie concrete to the bottom of the hole. Lean mix, concrete, and controlled density fill should not be end-dumped through water or slurry.
- The contractor should be prepared to excavate the soldier piles in a manner that prevents heave or boiling at the bottom of the soldier pile excavation. It may be possible to over-drill the borehole and backfill the bottom of the borehole with structural concrete bearing on undisturbed soil.
- Drilling mud should not be used unless reviewed and approved by Hart Crowser and the structural engineer.

- Soldier pile shoring construction may be difficult if cobbles or loose sand and gravel are encountered in the excavation. If these conditions are encountered, substantial soil raveling could occur. If raveling soils are encountered, we recommend shaft construction methods such as slurry or temporary casing be used to minimize raveling and loss of soil.

Lagging Installation

- Prompt and careful installation of lagging, particularly in areas of seepage and loose soil, is important to maintain the integrity of the excavation. The contractor should be prepared to place lagging in small vertical increments and should also be prepared to backfill voids caused by ground loss behind the shoring system. The proper installation should be the responsibility of the shoring contractor to prevent soil failure or sloughing and loss of ground, and to provide safe working conditions.
- Voids greater than 1 inch should be backfilled with sand, pea gravel, or a porous slurry. The void spaces progressively as the excavation deepens. The backfill must not allow potential hydrostatic pressure buildup behind the wall. Drainage behind the wall must be maintained or hydrostatic water pressure should be added to the recommended lateral earth pressures.
- If there is a slope above the wall, extra lagging should be installed above the shoring wall to provide a partial barrier for material that could ravel down from the slope face and fall into the excavation.

Tieback Installation

- Structural grout should be pumped into the anchor zone using a grout hose or tremie hose placed at the bottom of the anchor.
- The portion of the tieback in the no-load zone should be filled with a non-cohesive mixture of sand-pozzolan-water or equivalent; or, a bond breaker such as plastic sheathing or a PVC pipe should be installed around the tie rods within the no-load zone.
- Tiebacks should be grouted and backfilled immediately after placing the anchor. To prevent collapse of the holes, ground loss, and surface subsidence, anchor holes should not be left open overnight.
- Care should be taken not to mine out large cavities in granular soil.
- Continuous cutting return should be maintained if pneumatic drilling techniques are used, so that air pressure is not channeled to nearby utility vaults, corridors, or subgrade slabs, which may be damaged by air pressure.
- Anchors should be installed to minimize ground loss and previously installed anchors should not be disturbed. During tieback drilling, wet or saturated zones may be encountered and caving or

blow-in could occur. Drilling with a casing may reduce the potential for these conditions and ground loss.

- Tiebacks should be tested to confirm the appropriateness of the anchor design values and to verify that a suitable installation is achieved. The recommended procedures for verification and proof-testing are provided below.

Recommendations for Tieback Testing

The tieback anchor testing program should include verification testing of select tiebacks and proof testing of all production tiebacks. We recommend that tieback testing be done in general accordance with the recommendations in the publication Recommendations for Prestressed Rock and Soil Anchors by the Post Tensioning Institute (PTI 2004) and the recommendations below.

Verification Tests

We recommend a minimum of two verification tests per soil type before installation of production anchors to validate the design pullout value. The geotechnical engineer will select the testing locations with input from the shoring subcontractor. The geotechnical engineer or shoring designer may require additional verification tests when creep susceptibility is suspected or when varying ground conditions are encountered.

Verification tiebacks should be installed by the same methods and personnel, using the same material and equipment, as the production tiebacks; the engineer will determine whether deviations require additional verification testing. At least two successful verification tests should be performed for each installation method and each soil type.

Verification tests load the tieback to 200 percent of the DL and include a 60-minute hold time at 150 percent of the DL. The tieback DLs will be on the shoring drawings. The tieback load should not exceed 80 percent of the steel's ultimate tensile strength. Verification test tiebacks should be incrementally loaded and unloaded using the schedule in Table 11.

Table 11 – Tieback Verification Test Schedule

Load Level	Hold Time
Alignment load	Until stable
0.25DL	10 min
0.5DL	10 min
0.75DL	10 min
1.0DL	10 min
1.25DL	10 min
1.5DL	60 min
1.75DL	10 min
2.0DL	10 min

The alignment load should be the minimum load required to align the testing assembly and should be less than 5 percent of the DL. The dial gauge should be zeroed after the alignment load has stabilized. Perform a creep test at 1.5DL by holding the load constant to within 50 psi and recording deflections at 1, 2, 3, 5, 6, 10, 20, 30, 50, and 60 minutes.

The acceptance criteria for a verification test are:

- The creep rate at 1.5DL is less than 0.08 inches between 6 and 60 minutes and the creep rate is linear or decreasing during the creep test;
- The total tieback displacement is greater than 80 percent of the theoretical elastic elongation of the design unbonded length plus the jack length; and
- The anchor does not pull out under repeated loading.

Proof Tests

Proof tests load the tieback to 1.33DL and include a 10-minute hold time at 1.33DL. The tieback DLs should be on the shoring drawings. The tieback load should not exceed 80 percent of the steel's ultimate tensile strength. Proof tests should be incrementally loaded and unloaded using the schedule in Table 12.

Table 12 – Tieback Proof Test Schedule

Load Level	Hold Time
Alignment load	Until stable
0.25DL	1 min
0.5DL	1 min
0.75DL	1 min
1.0DL	1 min
1.33DL	10 min

The alignment load should be the minimum load required to align the testing assembly and should be less than 5 percent of the design load. The dial gauge should be zeroed after the alignment load has stabilized.

The load should be held constant to within 50 psi and deflections recorded at 1, 2, 3, 5, 6 and 10 minutes. If the tieback deflection between 1 and 10 minutes at 1.33DL exceeds 0.04 inches, the load should be held for an additional 50 minutes and deflections recorded at 20, 30, 50, and 60 minutes.

The acceptance criteria for a proof test are:

- The creep rate at 1.33DL is less than 0.04 inches between 1 and 10 minutes or less than 0.08 inches between 6 and 60 minutes and the creep rate is linear or decreasing during the creep test;

- The total tieback displacement is greater than 80 percent of the theoretical elastic elongation of the design unbonded length plus the jack length; and
- The anchor does not pull out under repeated loading.

Shoring Monitoring

A shoring monitoring program provides early warning if the shoring does not perform as expected. The monitoring program should include a preconstruction survey, periodic surveys during construction, and a post-construction survey.

Preconstruction Survey

A preconstruction survey documents the condition of existing streets, utilities, and buildings. The survey should include video and/or photographic documentation. The size and location of existing cracks in streets and buildings should receive special attention and may be monitored with a crack gauge.

Construction Survey

We recommend adjacent building surveys, optical survey, and inclinometer survey be included in the shoring monitoring program during construction.

All monitoring data should be submitted to Hart Crowser for weekly review. The data will be included in our field transmittals to the project team during construction. Details of our expectations for shoring monitoring are included below.

Adjacent Building Surveys. We recommend that adjacent buildings be surveyed before, during, and after construction. The pre-construction survey will establish the baseline of existing conditions (e.g., identifying the size and locations of any cracks). The surveys should consist of a videotape and/or photographs of the interior and exterior of adjacent buildings and detailed mapping of all cracks. Any existing cracks could be monitored with a crack gauge.

Optical Surveying. We recommend optical surveys of horizontal and vertical movements of: (1) the surface of the adjacent streets, (2) buildings on and adjacent to the site, and (3) the shoring system itself. The contractor, in coordination with the geotechnical engineer, should establish two reference lines adjacent to the excavation at horizontal distances back from the excavation face of about $1/3 H$ and H , where H is the final excavation height. Typically, these lines will be established near the curb line and across the street from the excavation face. The points on the adjacent buildings can be set either at the base or on the roof of the buildings.

Shoring system monitoring should include measuring vertical and horizontal movement at the top of every other soldier pile, and any geotechnical instrumentation (e.g., inclinometers) used for the project.

The measuring system for the shoring monitoring should have an accuracy of at least 0.01 foot. All reference points on the ground surface should be installed and read before excavation begins. The frequency of readings will depend on the results of previous readings and the rate of construction. At a minimum, readings on the external points should be taken twice a week through construction until below-grade structural elements (floors, decks, columns, etc.) are completed, or as specified by the structural and geotechnical engineers. Readings on the top of soldier piles and the face of existing buildings on or adjacent to the property should be taken at least twice a week during this time. We recommend that an independent surveyor hired by the owner to record the data at least once per week with the other reading taken by the surveyor or contractor.

Inclinometer. We recommend installing at least one inclinometer casing behind each shoring wall. The final number and location of the casings should be coordinated with Hart Crowser and the contractor. Hart Crowser can be hired to install the casings behind the shoring using a subcontracted driller; or, the shoring contractor may install the inclinometer casings. We recommend inclinometer surveys at least once per week during shoring construction. After the perimeter footing has been placed and cured, Hart Crowser may elect to reduce the inclinometer survey frequency.

Post-Construction Survey

A post-construction survey includes reviewing the preconstruction survey and comparing it to post-construction conditions. The survey should include video and/or photographic documentation. Changes in the number, size and location of cracks in streets and buildings should be given special attention.

Foundation Construction

Hart Crowser must observe exposed subgrades before footing construction begins to confirm design assumptions about subsurface conditions and subgrade preparation.

The exposed subgrade should be carefully prepared and protected before concrete placement. Considering the high allowable bearing pressures, any loosening of the materials during construction could result in more settlement. It is important that foundation excavations be cleaned of loose or disturbed soil before placing any concrete and that there is no standing water in any foundation excavation. These conditions should be observed by our representative.

Maintain groundwater levels at least 2 feet below the base grade of the footing excavation at all times to prevent the risk of heave, piping, boiling, and other loss or disturbance of subgrade material. This groundwater level should be maintained until after the footing steel and concrete are placed.

Any loose or soft soils that occurs naturally or is disturbed during construction should be overexcavated and replaced with structural for footings. Any visible organic and other unsuitable material should be removed from the exposed subgrade.

It may be necessary to place a 2- to 4-inch-thick lean or structural concrete mat in footing excavations to protect subgrade soil from being softened by water or construction activities after it is exposed. Concrete may only be placed after the geotechnical engineer has checked the subgrade.

Lean mix concrete should be in accordance with 2011 City of Seattle Standard Specifications Section 6-02.3(2)D. Lean concrete should contain between 145 and 200 pounds of cement per cubic yard and have a maximum water-to-cement ratio of 2.

Earthwork

Site Preparation and Grading

We recommend conducting all site grading, paving, and any utility trenching during relatively dry weather conditions.

It may be necessary to relocate or abandon some utilities. Excavation of these utility lines will probably occur through backfill. Abandoned underground utilities should be removed or completely grouted. Ends of remaining abandoned utility lines should be sealed to prevent piping of soil or water into the pipe. Soft or loose backfill should be removed, and excavations should be backfilled with structural fill. Coordination with the utility agency is generally required.

Structural Fill

Backfill placed within the building area or below paved areas should be considered structural fill. We recommend the following for structural fill:

- For imported soil to be used as structural fill, a clean, well-graded sand or sand and gravel with less than 5 percent by weight passing the No. 200 mesh sieve (based on the minus 3/4-inch fraction) should be used. Compaction of soil containing more than about 5 percent fines may be difficult if the material is wet or becomes wet during rainy weather.
- All structural fill should be placed and compacted in lifts with a loose thickness no greater than 10 inches. For hand-operated “jumping jack” compactors, loose lifts should not exceed 6 inches. For small vibrating plate/sled compactors, loose lifts should not exceed 3 inches.
- All structural fill should be compacted to at least 95 percent of the modified Proctor maximum dry density (as determined by ASTM D1557 test procedure).
- The moisture content of the fill should be controlled to within 2 percent of the optimum moisture. Optimum moisture is the moisture content corresponding to the maximum Proctor dry density.
- In wet subgrade areas, clean material with a gravel content of at least 30 to 35 percent may be necessary. Gravel is material coarser than a US No. 4 sieve.
- Before filling begins, samples of the structural and drainage fill should be provided for laboratory testing. Laboratory testing will include a Proctor test and gradation for structural fill and a

gradation for drainage fill. Field testing with a nuclear density gauge uses the maximum dry density determined from a Proctor test so it is important to complete the laboratory testing as soon as possible so backfilling is not delayed.

Use of On-Site Soil as Structural Fill

Our explorations indicated that the near-surface site soil includes silty sand, silt, and clay; we do not recommend using these soils for structural fill. The deeper sand and gravel soils may be used, but they are likely to contain more than 5 percent fines; they will be moisture-sensitive and could be difficult to compact in wet weather.

Temporary Cuts

Because of the variables involved, actual slope grades required for stability in temporary cut areas can only be estimated before construction. We recommend that stability of the temporary slopes used for construction be the sole responsibility of the contractor, since the contractor is in control of the construction operation and is continuously at the site to observe the nature and condition of the subsurface. Excavations should be made in accordance with all local, state, and federal safety requirements.

For planning purposes, the soils across the site are likely OSHA Soil Classification Type C; however, the soil classification must be reevaluated at the time of construction.

The stability and safety of open trenches and cut slopes depend on a number of factors, including:

- Type and density of the soil;
- Presence and amount of any seepage;
- Depth of cut;
- Proximity of the cut to any surcharge loads near the top of the cut, such as stockpiled material, traffic loads, or structures;
- Duration of the open excavation; and
- Care and methods used by the contractor.

Considering these factors, we recommend:

- Using plastic sheeting to protect slopes from erosion; and
- Limiting the duration of open excavations as much as possible.

RECOMMENDATIONS FOR CONTINUING GEOTECHNICAL SERVICES

Before construction begins, we recommend that Hart Crowser continue to meet with the design team as needed to address geotechnical questions that may arise throughout the remainder of the design and permitting process. We also recommend that Hart Crowser review the project plans and specifications to confirm that the geotechnical engineering recommendations have been properly interpreted.

During construction, we recommend that Hart Crowser be retained to perform the following tasks:

- Review contractor submittals;
- Observe shoring installation;
- Observe foundation installations;
- Observe foundation drainage installation;
- Perform other observations as required by the Seattle Department of Planning and Development;
- Attend meetings, as needed; and
- Provide geotechnical engineering support that may arise during construction.

REFERENCES

FHWA 1999. Geotechnical Engineering Circular No. 4, Ground Anchors and Anchored Systems. FHWA-IF-99-015. June 1999.

IBC 2012. International Building Code. International Code Council.

PTI 2004. Recommendations for Prestressed Rock and Soil Anchors, Third Edition. Post Tensioning Institute.



Source: Base map prepared from ArcGIS Online, 2013.

EAL 12/3/14 1798401-001.dwg

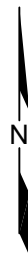
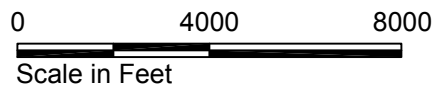

Mercer Island Multi-Family Development
Mercer Island, Washington

Vicinity Map

17984-01

12/14



Figure

1

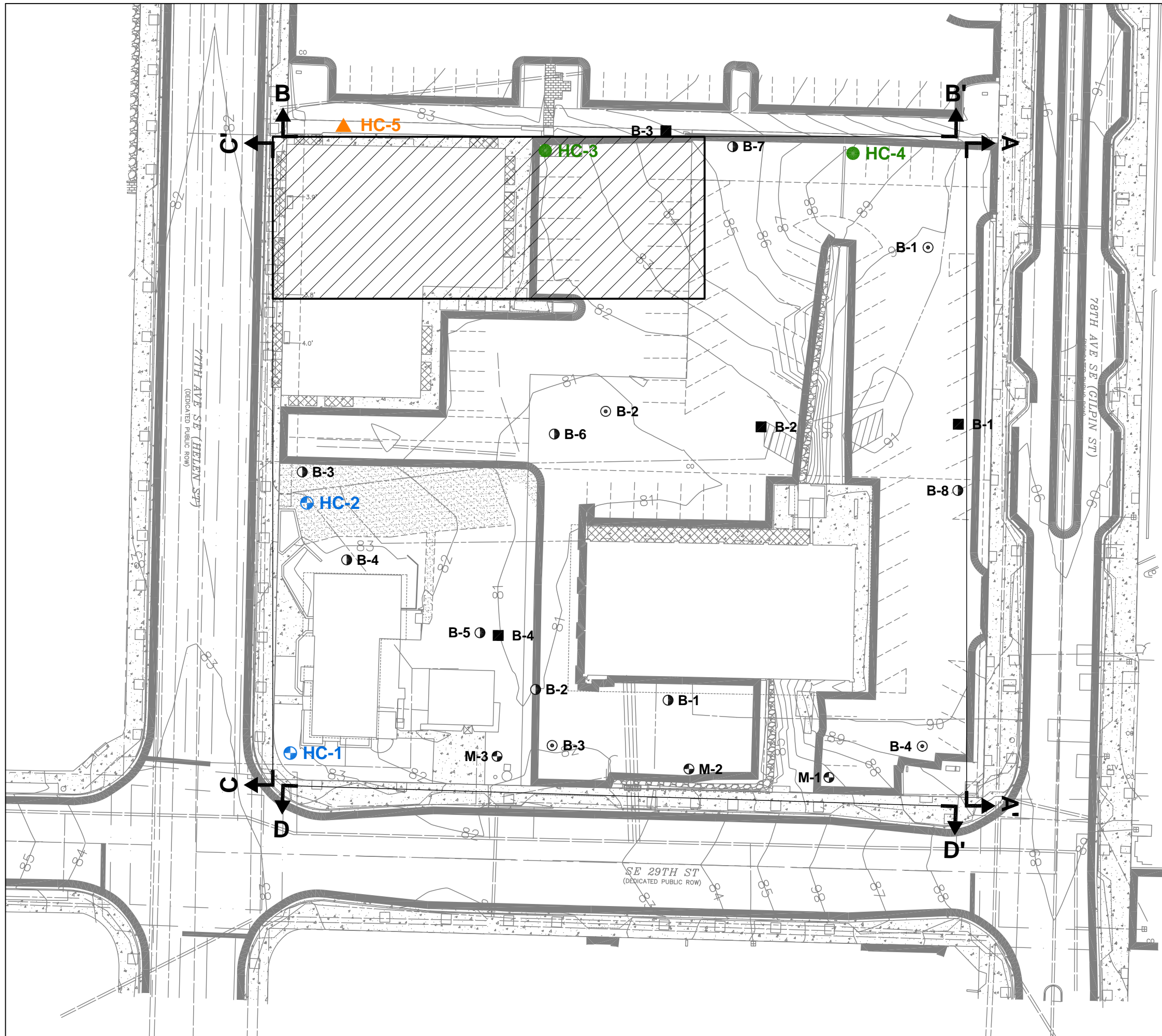

- Current Exploration Location and Number
- HC-3 ● Boring (Hart Crowser)
 - HC-5 ▲ Hand Probe (Hart Crowser)
 - HC-1 ● Monitoring Well (Hart Crowser)

- Previous Exploration Location and Number
- B-1 ■ Boring (ABPB Consulting)
 - B-6 ● Push Probe (Farallon)
 - M-1 ● Monitoring Well (ABPB Consulting)
 - B-1 ⊙ Boring (Terra)

A A' Approximate Cross Section Location and Designation

Approximate Ramp Location

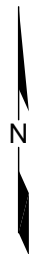
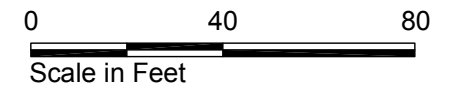

Source: Base map prepared from survey "XS-ALTA-02.dwg," created by Bush, Roed & Hitchings, dated 10/14/14.

Mercer Island Multi-Family Development
Mercer Island, Washington

Site and Exploration Plan

17984-01

4/15



Figure

2

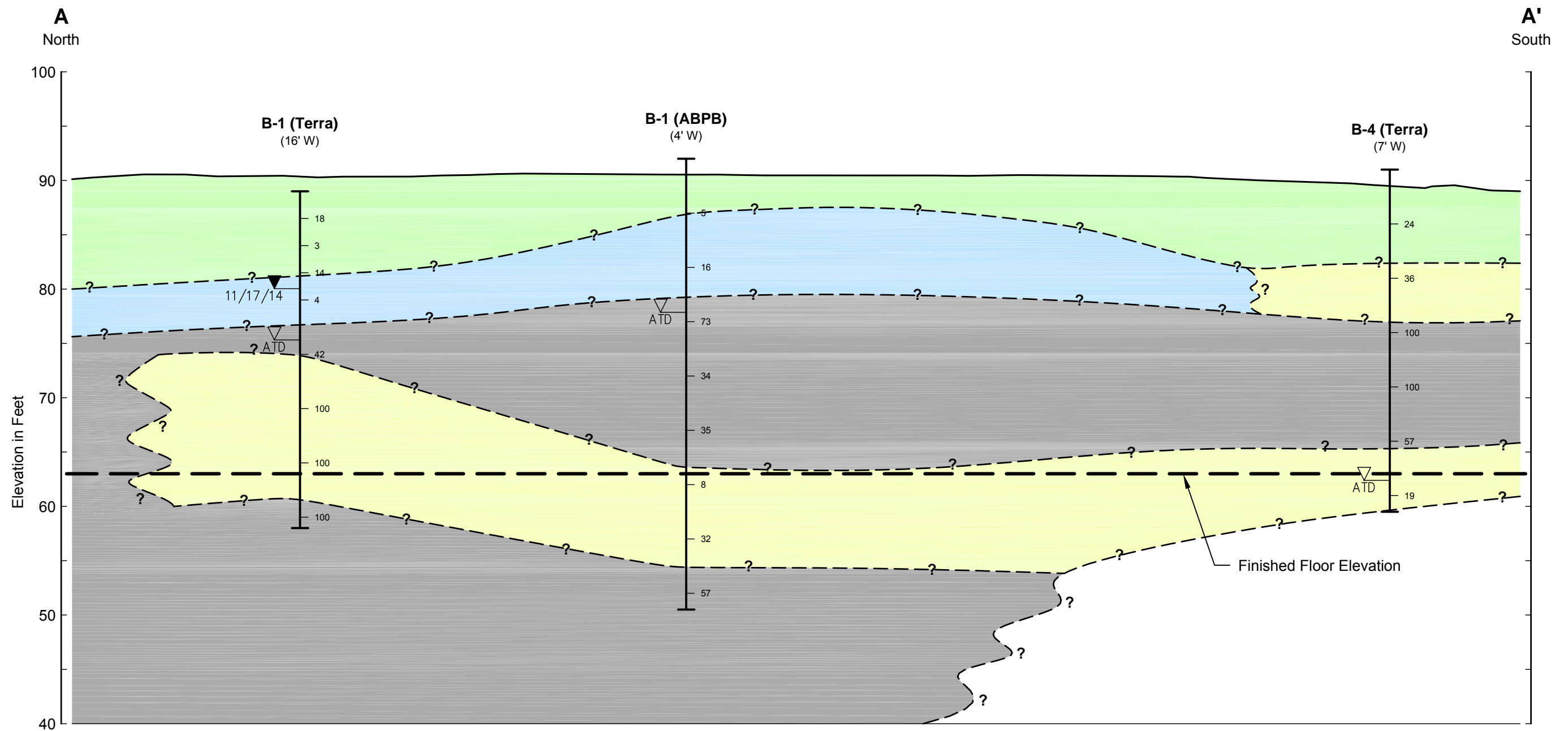

B-1 (Terra) Exploration Number
(16' W) (Offset Distance and Direction)

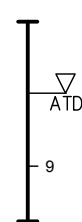

Exploration Location

Water Level

Standard Penetration Resistance in Blows per Foot

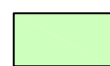

Unit 1
Loose to medium dense granular FILL, soft SILT, and PEAT



Unit 2
Medium stiff to hard SILT and silty CLAY

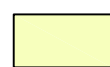

Unit 3
Medium dense to dense SAND and silty SAND



Unit 4
Hard SILT

Horizontal Scale in Feet
0 20 40
Vertical Scale in Feet
0 10 20
Vertical Exaggeration x 2

Mercer Island Multi-Family Development
Mercer Island, Washington

Generalized Subsurface Cross Section A-A'

17984-01

4/15



Figure

3

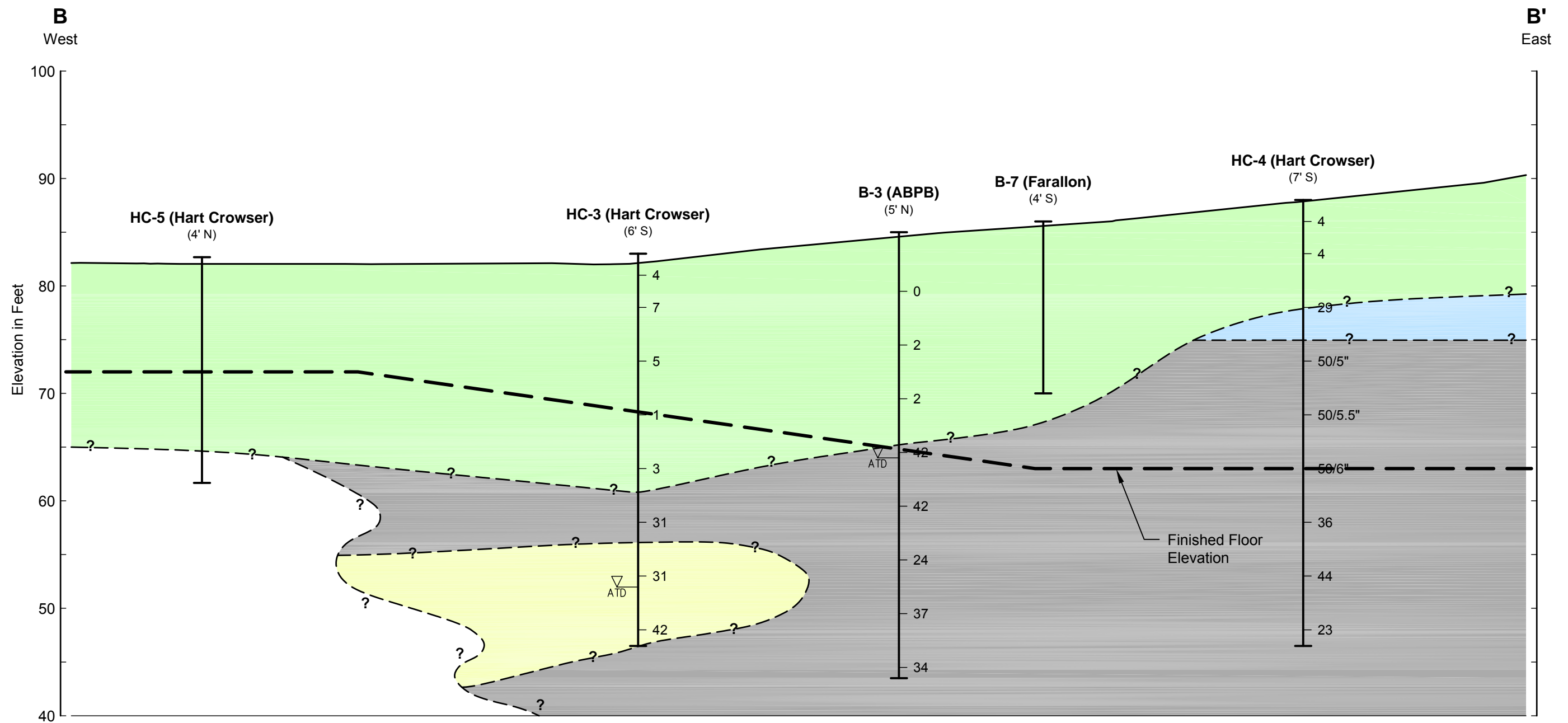

B-1 (Terra) Exploration Number
(16' W) (Offset Distance and Direction)

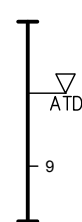

Exploration Location

Water Level

Standard Penetration Resistance in Blows per Foot

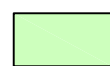

Unit 1
Loose to medium dense granular FILL, soft SILT, and PEAT



Unit 2
Medium stiff to hard SILT and silty CLAY



Unit 3
Medium dense to dense SAND and silty SAND



Unit 4
Hard SILT

Horizontal Scale in Feet
0 20 40
Vertical Scale in Feet
0 10 20
Vertical Exaggeration x 2

Mercer Island Multi-Family Development
Mercer Island, Washington

Generalized Subsurface Cross Section B-B'

17984-01

4/15



Figure

4

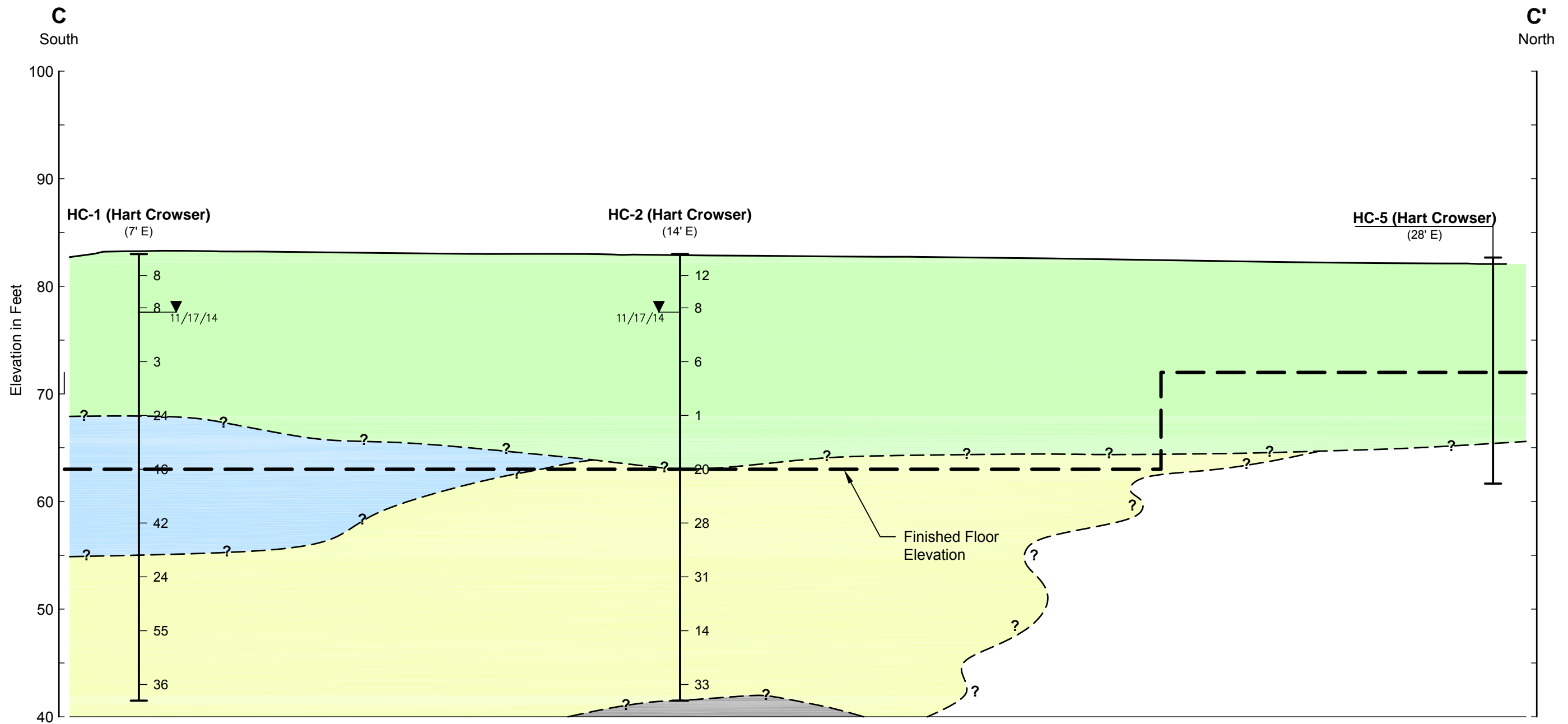

B-1 (Terra) Exploration Number
(16' W) (Offset Distance and Direction)

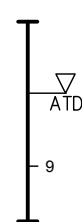

Exploration Location
Water Level
Standard Penetration Resistance in Blows per Foot

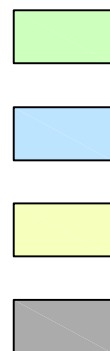

Unit 1
Loose to medium dense granular FILL, soft SILT, and PEAT

Unit 2
Medium stiff to hard SILT and silty CLAY

Unit 3
Medium dense to dense SAND and silty SAND

Unit 4
Hard SILT

Horizontal Scale in Feet
0 20 40
Vertical Scale in Feet
0 10 20
Vertical Exaggeration x 2

Mercer Island Multi-Family Development
Mercer Island, Washington

Generalized Subsurface Cross Section C-C'

17984-01

4/15



Figure

5

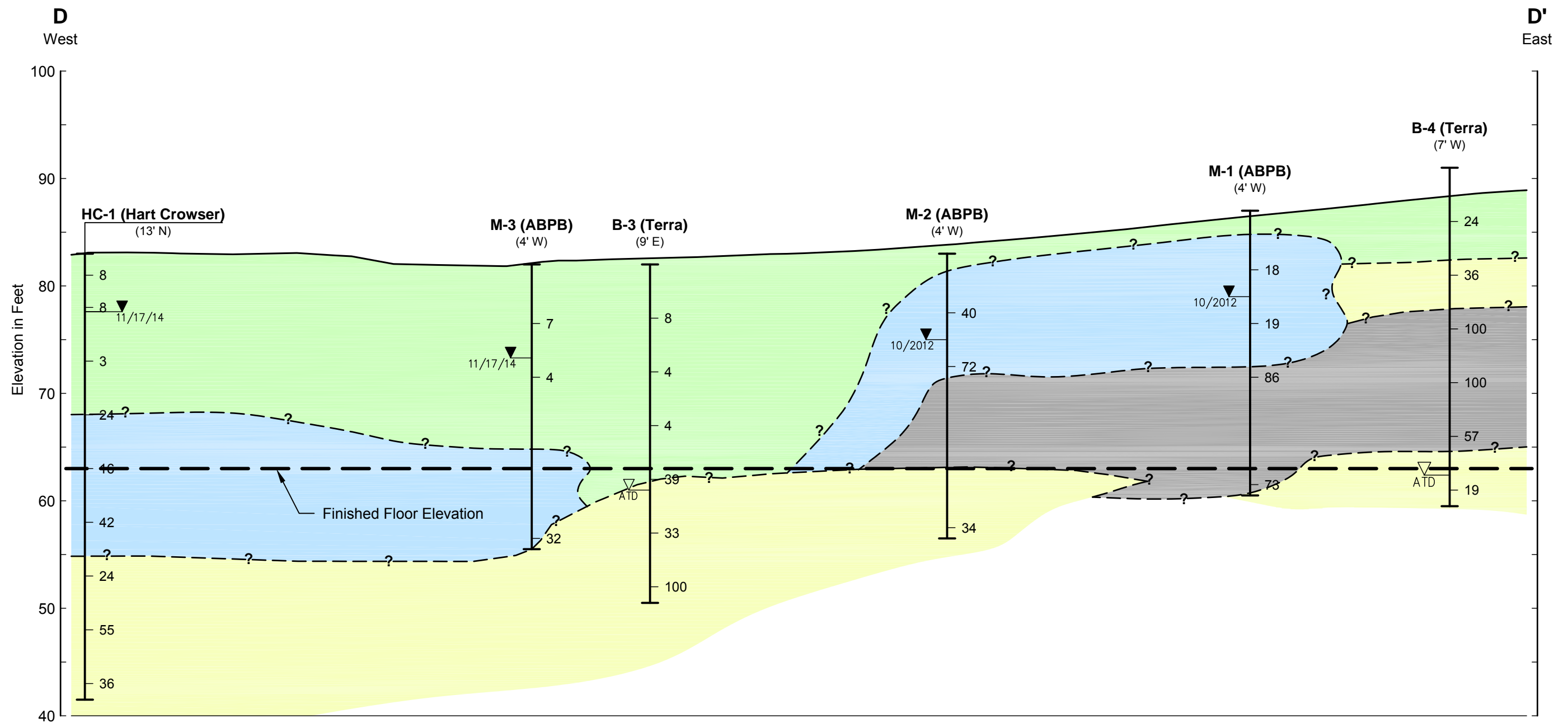

B-1 (Terra) (16' W) Exploration Number (Offset Distance and Direction)

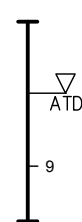

- Unit 1**
Loose to medium dense granular FILL, soft SILT, and PEAT
- Unit 2**
Medium stiff to hard SILT and silty CLAY
- Unit 3**
Medium dense to dense SAND and silty SAND
- Unit 4**
Hard SILT

Horizontal Scale in Feet
0 20 40

Vertical Scale in Feet
0 10 20
Vertical Exaggeration x 2

Mercer Island Multi-Family Development Mercer Island, Washington	
Generalized Subsurface Cross Section D-D'	
17984-01	4/15
	Figure 6

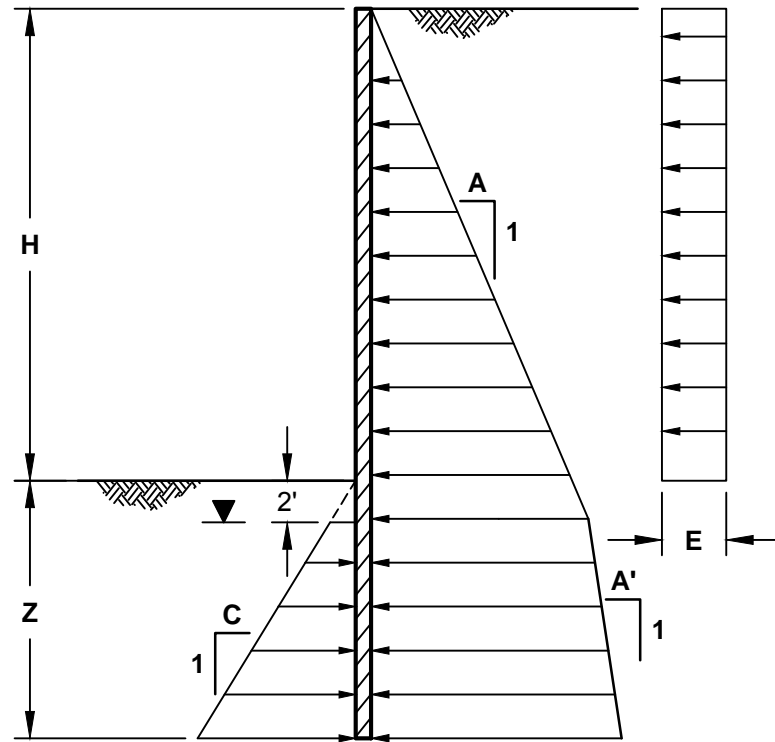

Passive Earth Pressure Active Earth Pressure Uniform Surcharge Pressure

Cantilever Soldier Pile

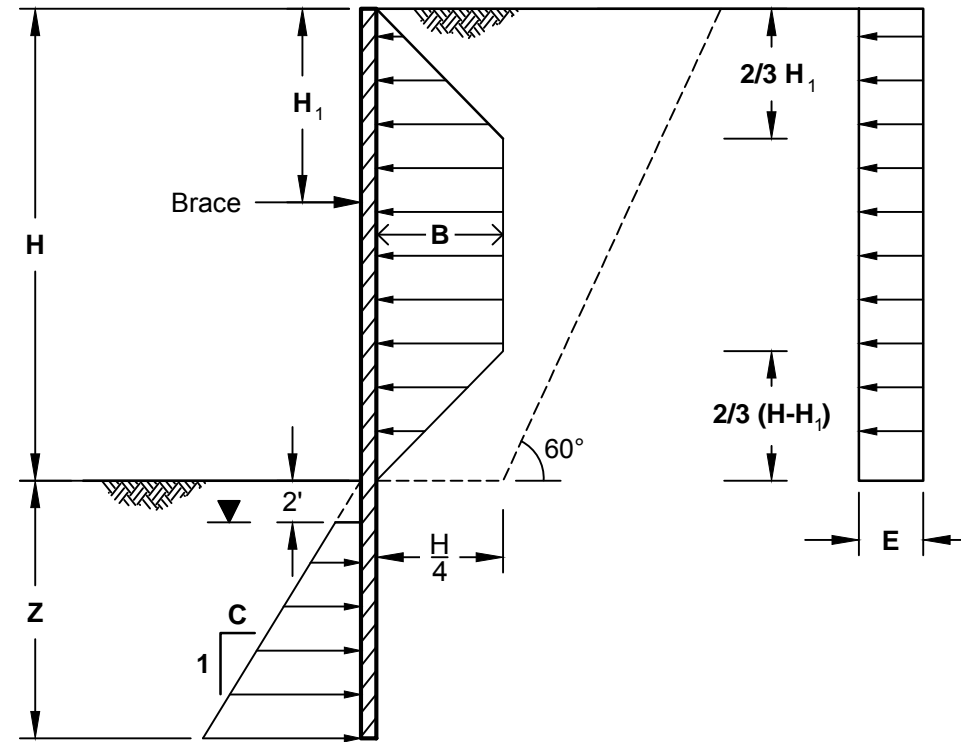

Passive Earth Pressure Apparent Earth Pressure Uniform Surcharge Pressure

Single Braced Wall

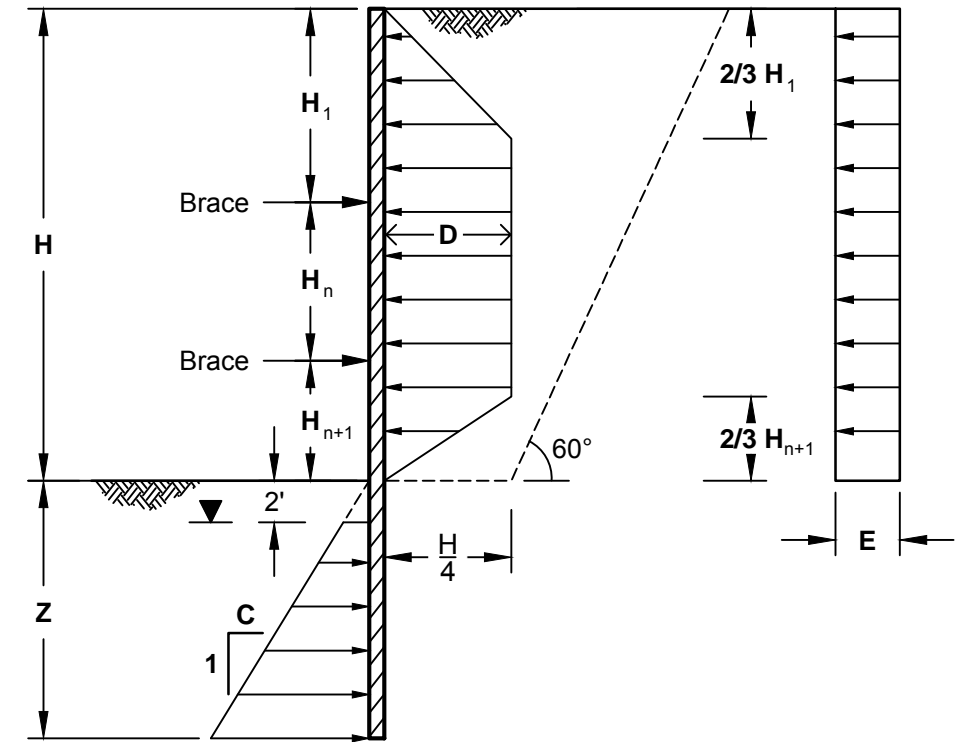

Passive Earth Pressure Apparent Earth Pressure Uniform Surcharge Pressure

Multiple Braced Wall

Recommended Lateral Earth Pressures

	A (Above GWT)	A' (Below GWT)	B	C (Above GWT)	C (Below GWT)	D	E
Active	42 pcf	21 pcf	42H psf	-	-	30H psf	85 psf
At-Rest	60 pcf	30 pcf	60H psf	-	-	45H psf	125 psf
Passive	-	-	-	300 pcf	175 pcf	-	-

Notes:

- All earth pressures are in units of pounds per square foot.
- Minimum recommended embedment (D) is 8 feet.
- Passive pressures are allowable values and include a 1.5 factor of safety.
- Passive pressure acts over 2.5 times the concreted diameter of the soldier pile or the the pile spacing, whichever is less.
- Apparent earth pressure, active earth pressure, and surcharge act over the pile spacing above the base of the excavation.
- Active pressure acts over the pile diameter below the excavation.
- Additional surcharge from footings, large stockpiles, heavy equipment, etc., must be added to these pressures.
- All dimensions are in feet.
- Diagrams are not to scale.

Legend

- H Total Height of Excavation, Feet
- H₁ Depth to Uppermost Tieback, Feet
- H_n Height Between Tiebacks, Feet
- H_{n+1} Distance from Base of Excavation to Lowermost Tieback, Feet
- Z Embedment Depth, Feet
- A,B,C, ... Earth Pressure Factors, See Table
- No-Load Zone
- ▼ Groundwater Table (GWT)

Mercer Island Multi-Family Development
Mercer Island, Washington

**Lateral Earth Pressures
Temporary Shoring**

17984-01 12/14

HARTCROWSER

Figure
7

**A. Strip Footing
Cross Section View**

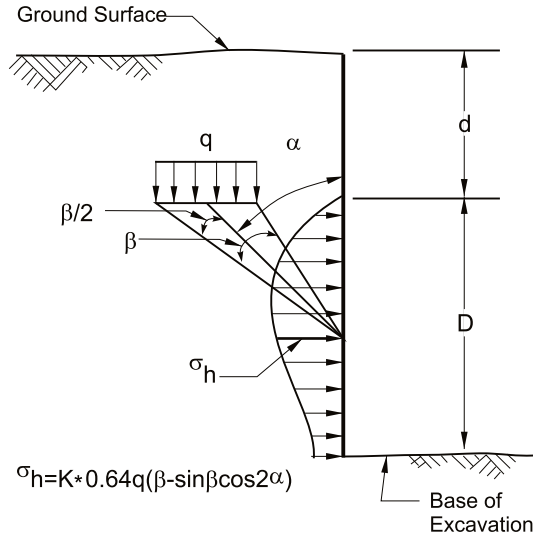

**B(1). Small Isolated Footing
Cross Section View**

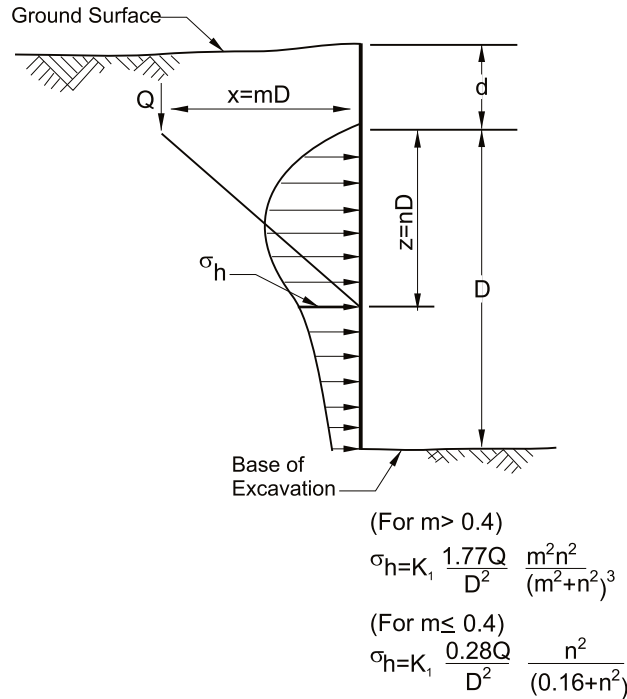

B(2). Plan View

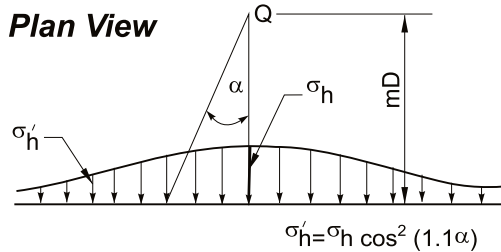

**C. Continuous Wall Footing
Parallel to Excavation
Cross Section View**

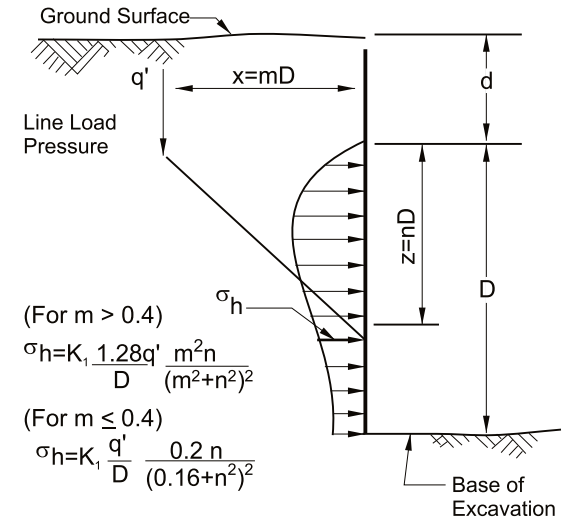

Definition and Units

- Q Footing Load in Pounds
- D Excavation Depth below Footing in Feet
- d Depth to Base of Footing in Feet
- σ_h Lateral Soil Pressure in PSF
- q Unit Loading Pressure in PSF
- q' Footing Load in Pounds per Foot
- α, β Radians

K_1	Conditions
0.35	Active earth pressure on a flexible wall (e.g., shoring)
0.5	At-rest conditions, where surcharge loads exist prior to excavation
1.0	At-rest conditions, where surcharge loads are applied after construction of permanent wall

- Notes:
1. Lateral pressures from adjacent structures should be added to lateral pressures on Figures 7 and 9.
 2. Wall footings acting other than parallel to the excavation can be treated as series of discrete point loads, using Approach B.
 3. Contact Hart Crowser for surcharge recommendations, if necessary.

Mercer Island Multi-Family Development
Mercer Island, Washington

Surcharge Pressures Determination of Lateral
Pressure Acting on Adjacent Shoring

17984-01

HART CROWSER

Figure 8
12/14

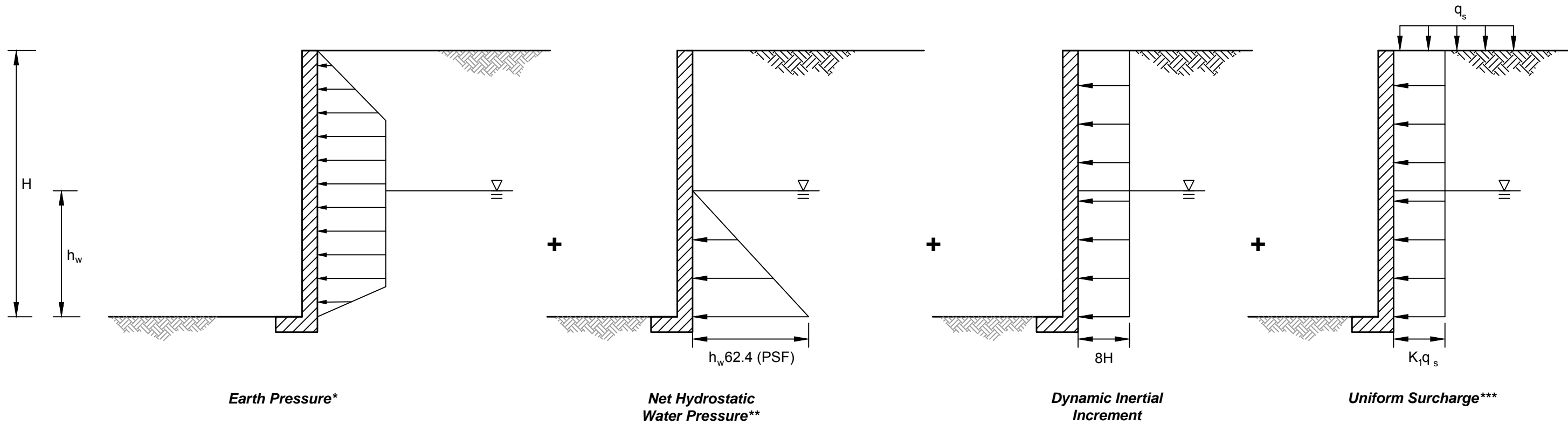

* The same earth pressure distributions determined for temporary shoring should be used for permanent walls constructed against shoring (See Figure 7).

** Neglect water pressure if permanently drained

*** See Figure 8 for K_1

Legend

- H Height from bottom of excavation to ground surface in feet
- q_s Traffic surcharge
- h_w Depth of excavation below groundwater table
- ∇ Groundwater table

Notes

1. All pressures are in units of pounds per square foot.
2. Diagrams do not include surcharge loading due to adjacent structures; see Figure 8.
3. Diagrams not to scale.

Mercer Island Multi-Family Development Mercer Island, Washington	
Lateral Pressures for Permanent Walls Constructed Against Shoring	
17984-01	12/14
	Figure 9

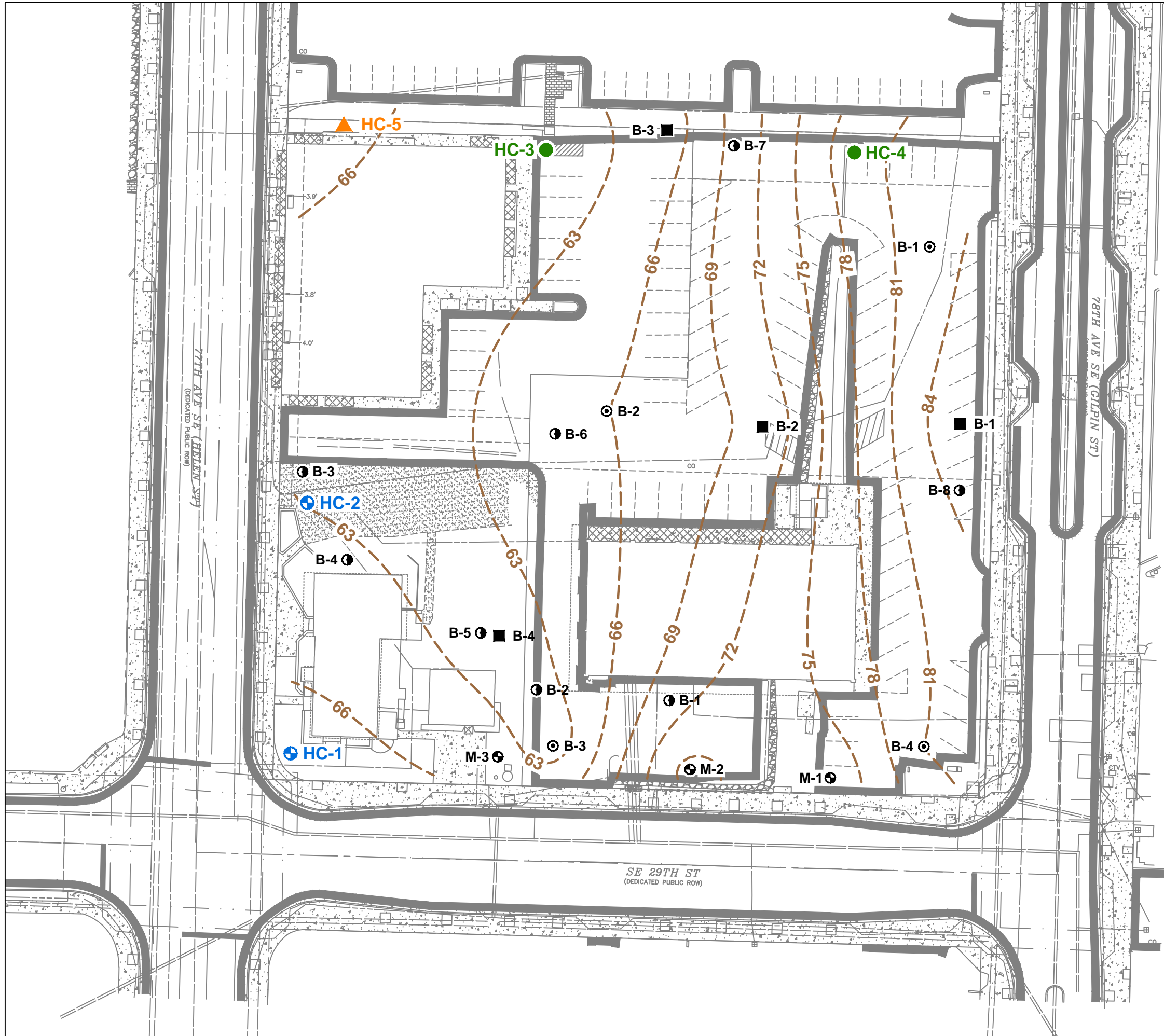

- Current Exploration Location and Number**
- HC-3** ● Boring (Hart Crowser)
 - HC-5** ▲ DCP (Hart Crowser)
 - HC-1** ⊕ Monitoring Well (Hart Crowser)

- Previous Exploration Location and Number**
- B-1** ■ Boring (ABPB Consulting)
 - B-6** ⊕ Push Probe (Farallon)
 - M-1** ⊕ Monitoring Well (ABPB Consulting)
 - B-1** ⊙ Boring (Terra)

84 - - - Top of Competent Soils Contour Elevation in Feet

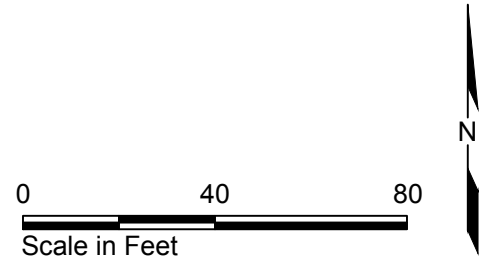

Source: Base map prepared from survey "XS-ALTA-02.dwg," created by Bush, Roed & Hitchings, dated 10/14/14.

Mercer Island Multi-Family Development Mercer Island, Washington	
Elevation of Top of Competent Soils	
17984-01	12/14
	Figure 10

EAL 12/10/14 1798401-010.dwg

ATTACHMENT 1
Slug Test Results

MEMORANDUM

DATE: December 12, 2014

TO: Hines

FROM: Angie Goodwin, LHG
Roy Jensen, LHG

RE: **Summary of Mercer Island Multi-Family Development Slug Test Results
Mercer Island, Washington
17984-01**

This technical memorandum presents the results of slug testing that was conducted for the Mercer Island Multi-Family Development in Mercer Island, Washington. The development is located on the northwest corner of the intersection of SE 29th Street and 78th Avenue SE. We understand that current development plans include one to two stories of below grade parking and five levels of housing and mixed-use space plus rooftop mechanical equipment. Slug tests were performed to determine hydraulic conductivity of formation for use in estimating flow rates during dewatering.

Slug tests are performed by suddenly inserting or removing a solid PVC rod in a well and measuring the recovery of the water levels during the test. A test conducted by the insertion of the PVC rod into the well is referred to as a falling head test and the following removal of the rod is called a rising head test. The water level data generated from the tests were analyzed using the commercial software Aquifer^{Win32} Version 3 (Environmental Simulations, Inc., 2003). The slug test analysis is based on the Bouwer and Rice method (Bouwer and Rice 1976; Bouwer 1989) to obtain an estimated value of hydraulic conductivity of the aquifer.

Slug Testing Results

Slug testing was conducted in wells HC-1, HC-2, ABPB-M3, and Terra-B1 on November 17, 2014. A summary of monitoring well construction details is provided in Table 1. Shallow soils at the project site consist of Fill, silty Sand, and Silt units. The wells were screened in two stratigraphic units and are summarized below:

- HC-1 was screened in the Silt and silty Sand units;
- HC-2 was screened in the silty Sand unit;



- ABPB-M3 boring log did not identify the screened interval, but it was assumed the well was screened in the Silt and silty Sand units; and
- Terra-B1 was screened in the Silt unit.

A summary of slug testing results is provided in Table 2. The slug test plots are provided as Figures 1 through 6. Multiple sets of falling and rising head tests were performed on each well. The results of the falling and rising head tests compare favorably. Average hydraulic conductivities determined from slug tests range from 9.0×10^{-5} to 8.3×10^{-4} cm/sec (0.3 to 2.4 feet/day). This hydraulic conductivity range is typical for silt and silty sand (Freeze and Cherry 1979).

References

Bouwer H. 1989. The Bouwer and Rice Slug Test – An Update. *Ground Water* 27(3): 304-309.

Bouwer H. and R.C. Rice 1976. A Slug Test for Determining Hydraulic Conductivity of Unconfined Aquifers with Completely or Partially Penetrating Wells. *Water Resources Research* 12(3): 423-428.

Environmental Simulations, Inc. 2003. Guide to Using Aquifer^{Win32} Version 3.

Freeze, R.A. and J.A. Cherry 1979. *Groundwater*. Prentice-Hall, Englewood Cliffs, New Jersey.

Attachments:

Table 1 – Monitoring Well Construction Summary

Table 2 – Summary of Slug Test Results

Figure 1 – HC-1 and HC-2 Hydrographs

Figure 2 – ABPB-M3 and Terra-B1 Hydrographs

Figure 3 – HC-1 Representative Slug Tests Results

Figure 4 – HC-2 Representative Slug Tests Results

Figure 5 – ABPB-M3 Representative Slug Tests Results

Figure 6 – Terra-B1 Representative Slug Tests Results

Table 1 - Monitoring Well Construction Summary

Well ID	HC-1	HC-2	ABPB-M3	Terra-B1
Boring Depth in Feet	41.5	41.5	26.5	31
Well Depth in Feet	40	39	25	17
Screen Interval Depth in Feet	20 to 40	29 to 39	NA	7 to 17
Depth to Sediment in Feet (1)	39.95	36.74	23.10	16.54
Depth to Water in Feet (1)	5.38	5.43	2.75	8.71
Saturated Thickness in Feet	35	31	20	8
Screened Interval Soil Description	ML - SM	SM	ML - SM	ML

Notes:

(1) Depth to sediment and depth to water was measured on November 17, 2014.

SM = Silty SAND

ML = Sandy SILT

NA = Data not available.

Table 2 - Summary of Slug Test Results

Well ID	Test Type	Test Number	Bouwer and Rice	
			K in ft/day	K in cm/sec
HC-1	Falling Head	Test 1	0.3	1.1E-04
	Rising Head	Test 1	0.4	1.4E-04
	Falling Head	Test 2	0.3	1.2E-04
	Rising Head	Test 2	0.4	1.5E-04
	Falling Head	Test 3	0.4	1.5E-04
	Rising Head	Test 3	0.4	1.5E-04
	Falling Head	Test 4	0.4	1.4E-04
	Rising Head	Test 4	0.4	1.5E-04
		<i>Average</i>	<i>0.4</i>	<i>1.4E-04</i>
HC-2	Falling Head	Test 1	2.4	8.4E-04
	Rising Head	Test 1	2.6	9.2E-04
	Falling Head	Test 2	2.1	7.5E-04
	Rising Head	Test 2	2.2	7.7E-04
	Falling Head	Test 3	2.6	9.3E-04
	Rising Head	Test 3	2.4	8.6E-04
	Falling Head	Test 4	1.9	6.6E-04
	Rising Head	Test 4	2.7	9.4E-04
		<i>Average</i>	<i>2.4</i>	<i>8.3E-04</i>
ABPB-M3	Falling Head	Test 1	1.8	6.3E-04
	Rising Head	Test 1	1.8	6.2E-04
	Falling Head	Test 2	1.8	6.5E-04
	Rising Head	Test 2	1.9	6.6E-04
	Falling Head	Test 3	1.6	5.7E-04
	Rising Head	Test 3	1.9	6.8E-04
	Falling Head	Test 4	1.9	6.7E-04
	Rising Head	Test 4	2.1	7.3E-04
		<i>Average</i>	<i>1.8</i>	<i>6.5E-04</i>
Terra-B1	Falling Head	Test 1	0.2	5.7E-05
	Rising Head	Test 1	0.5	1.8E-04
	Falling Head	Test 2	0.1	3.1E-05
	Rising Head	Test 2	0.3	1.2E-04
	Falling Head	Test 3	0.2	5.3E-05
	Rising Head	Test 3	0.3	1.1E-04
	Falling Head	Test 4	0.2	6.5E-05
	Rising Head	Test 4	0.3	1.0E-04
		<i>Average</i>	<i>0.3</i>	<i>9.0E-05</i>

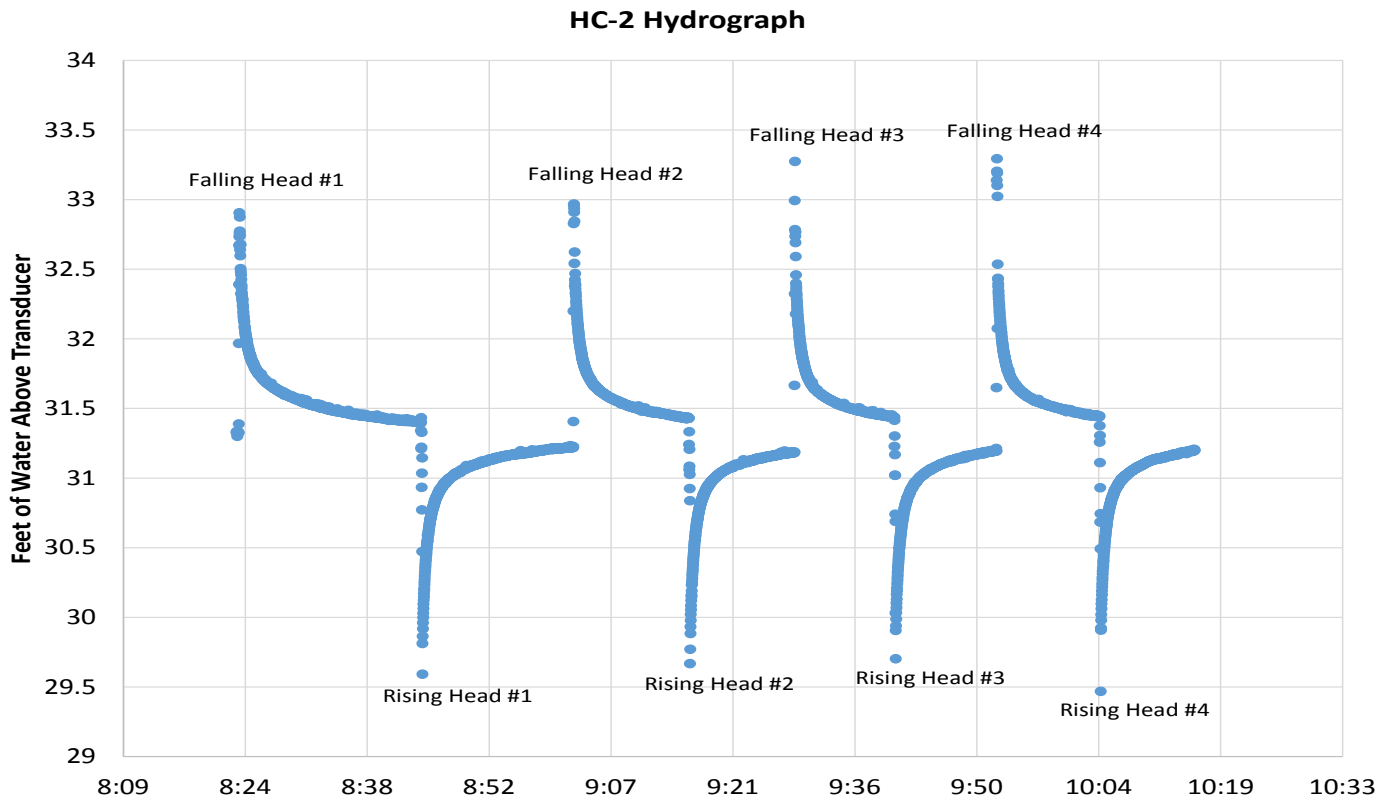
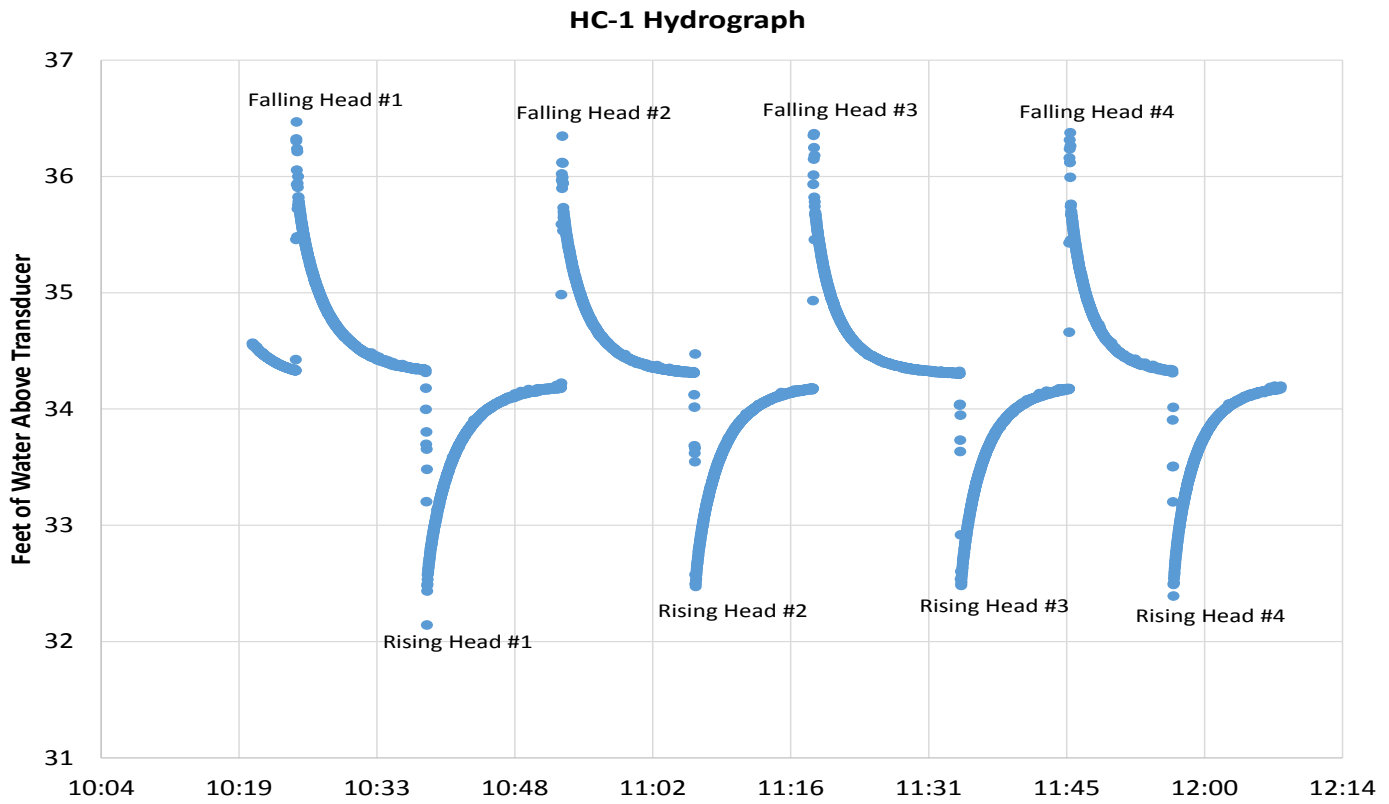

Mercer Island Multi-Family Development
Mercer Island, Washington

HC-1 and HC-2 Hydrographs

17984-01

12/14



Figure

1

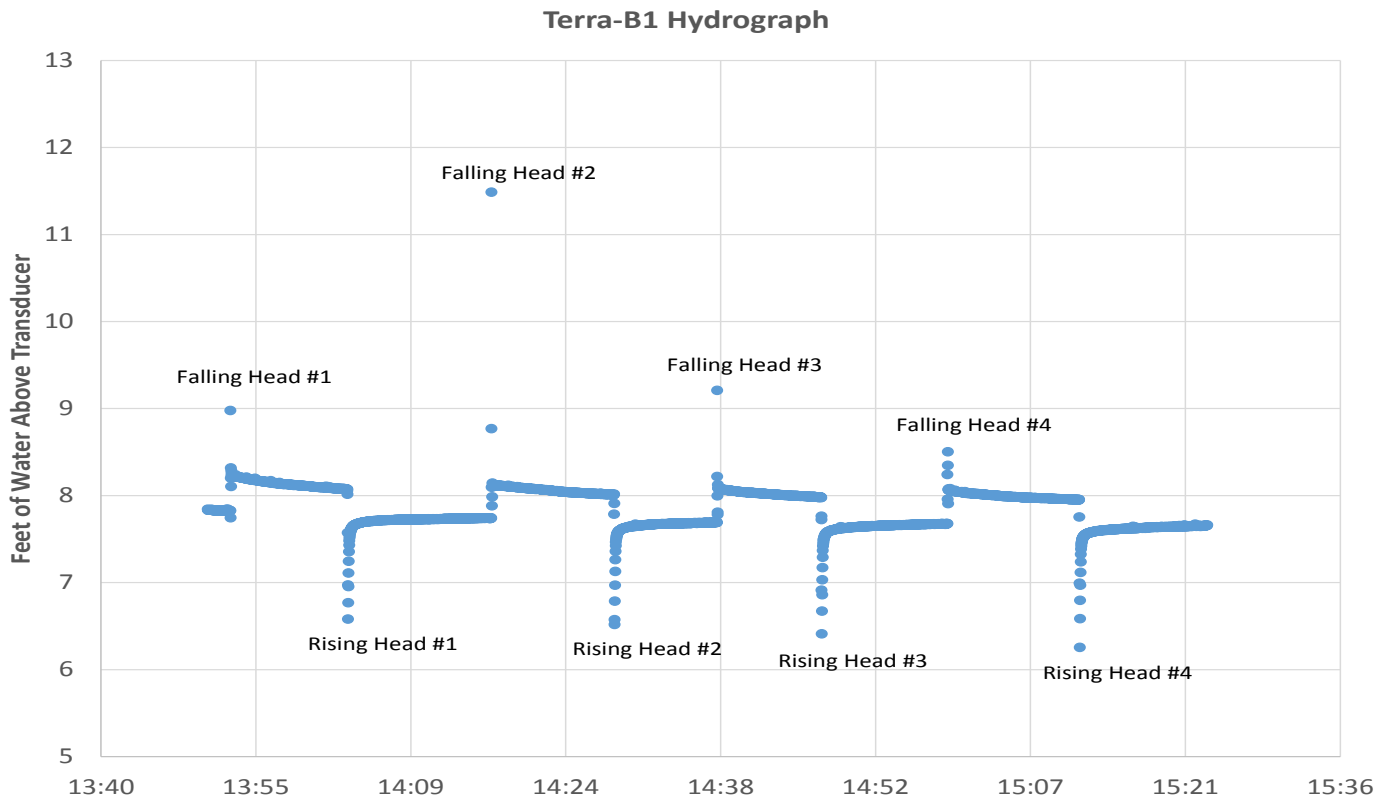
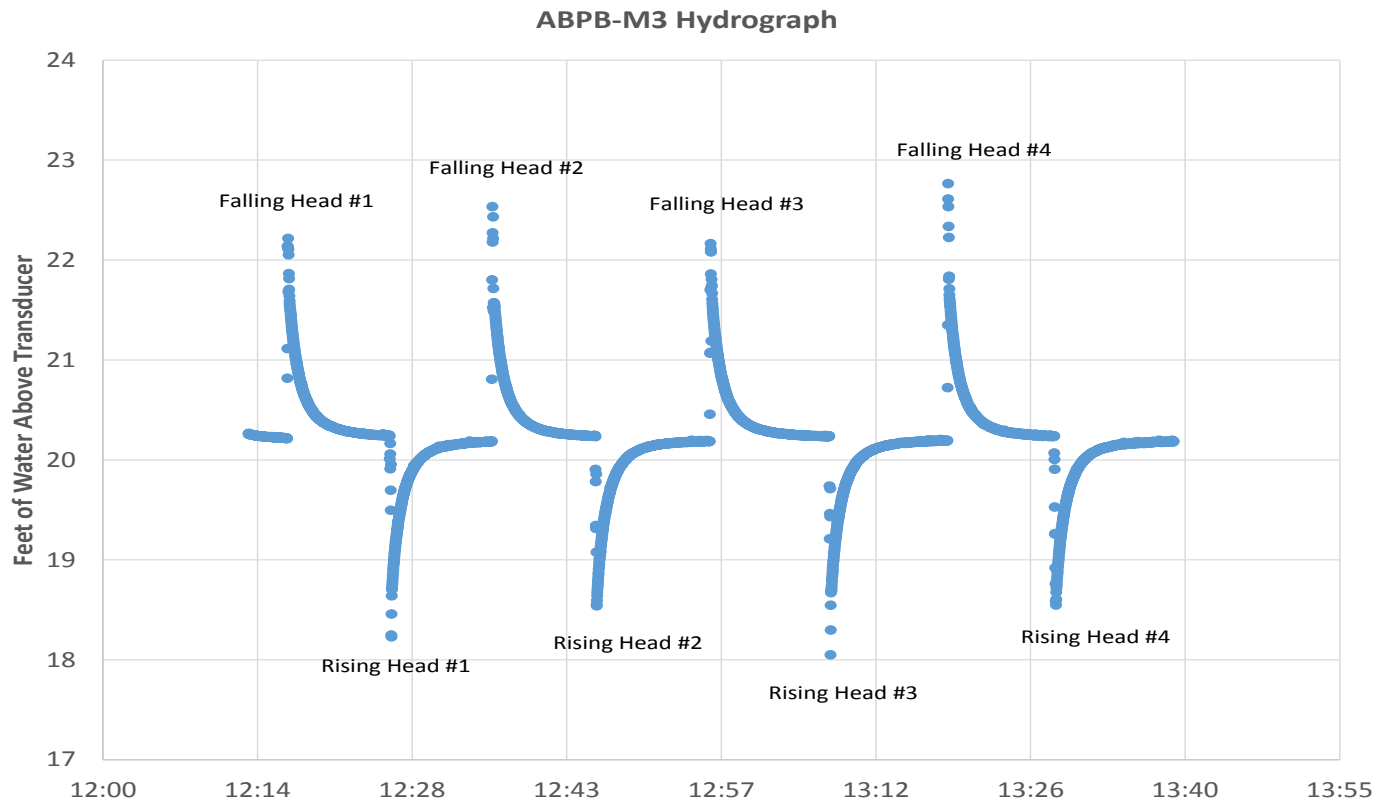

Mercer Island Multi-Family Development
Mercer Island, Washington

ABPB-M3 and Terra B-1 Hydrographs

17984-01

12/14



Figure

2

HC-1 Falling Head Test #1

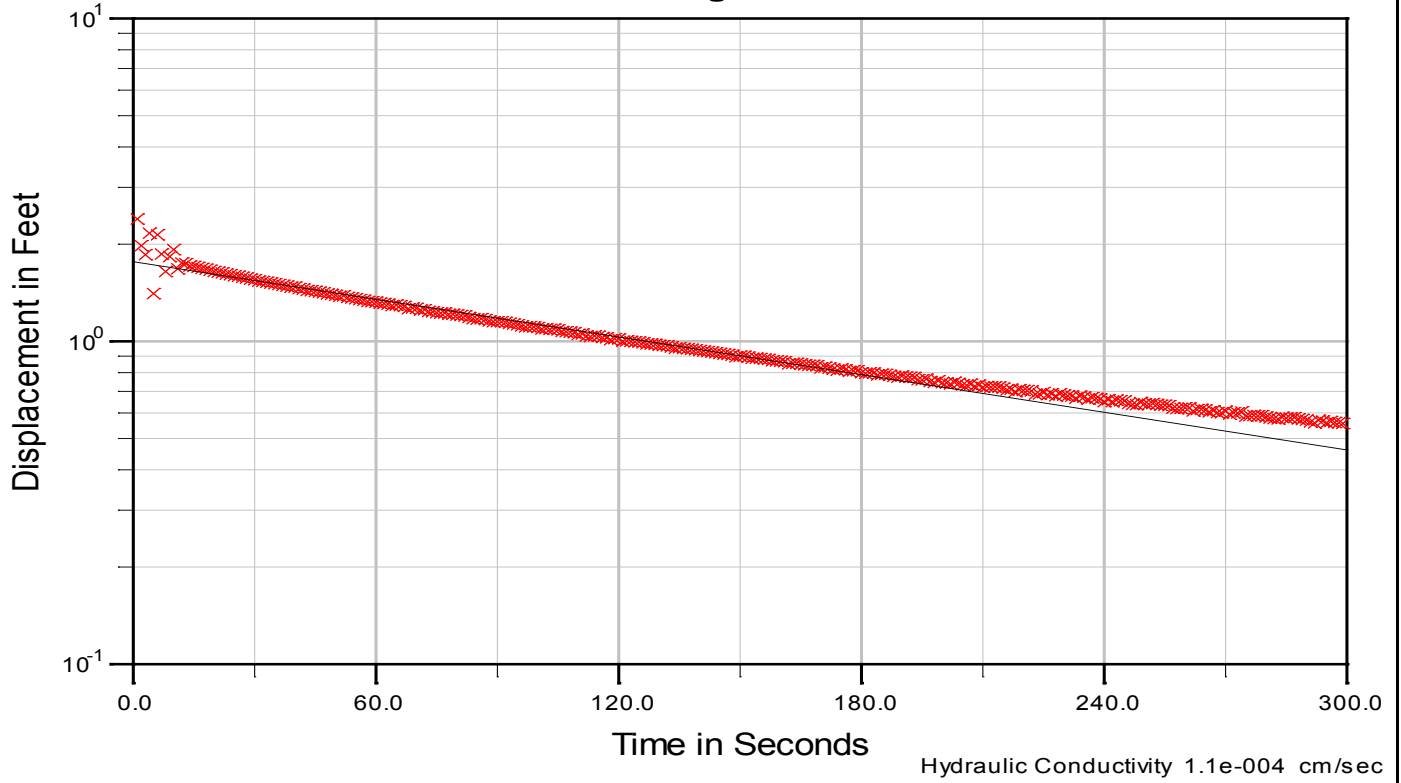

HC-1 Rising Head #1

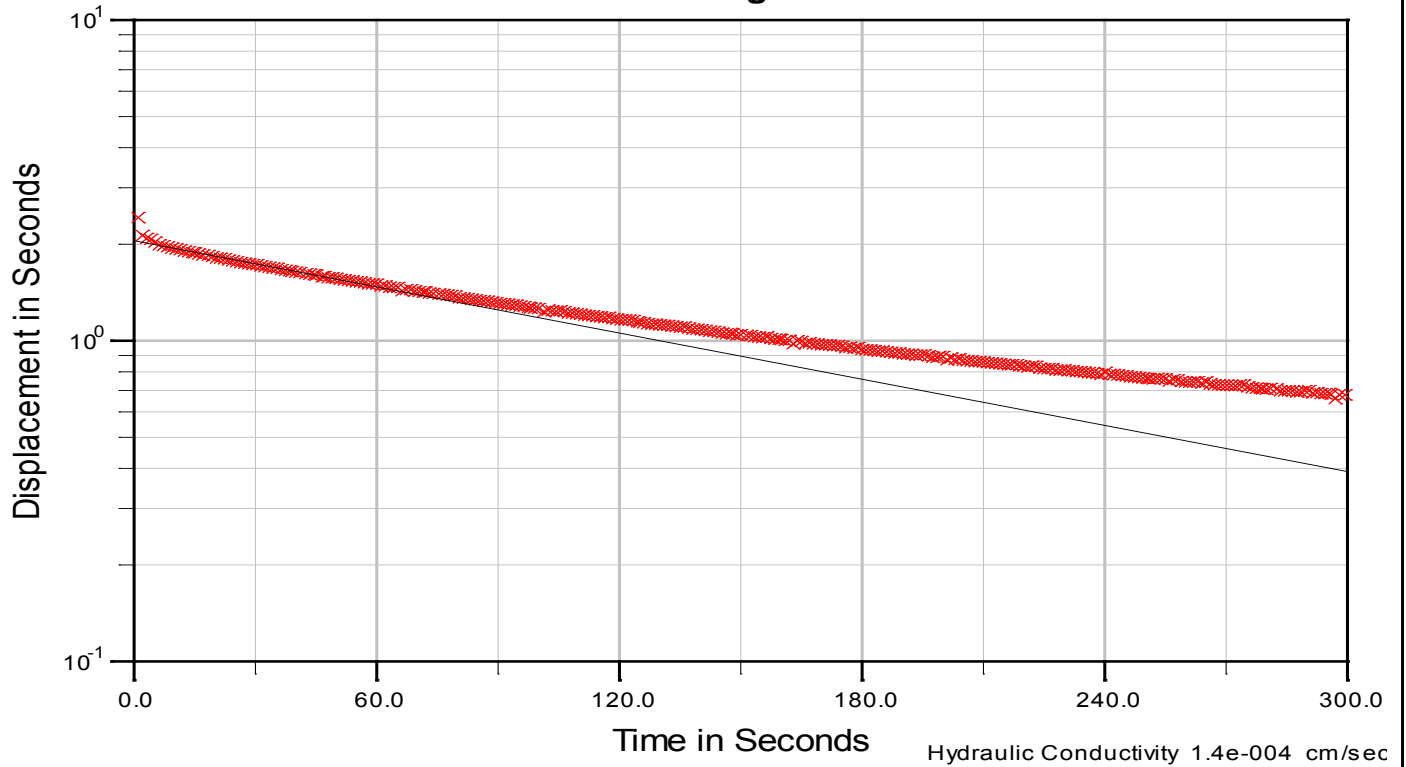

A:\J 12/11/14 L:\Project Notebook\1798401 Mercer Island Multi family\Slug-test\Files\Slug Test

Note:
Bouwer and Rice method was used for the slug test analysis.

Mercer Island Multi-Family Development
Mercer Island, Washington

HC-1 Representative Slug Tests Results

17984-01

12/14



Figure

3

HC-2 Falling Head #1

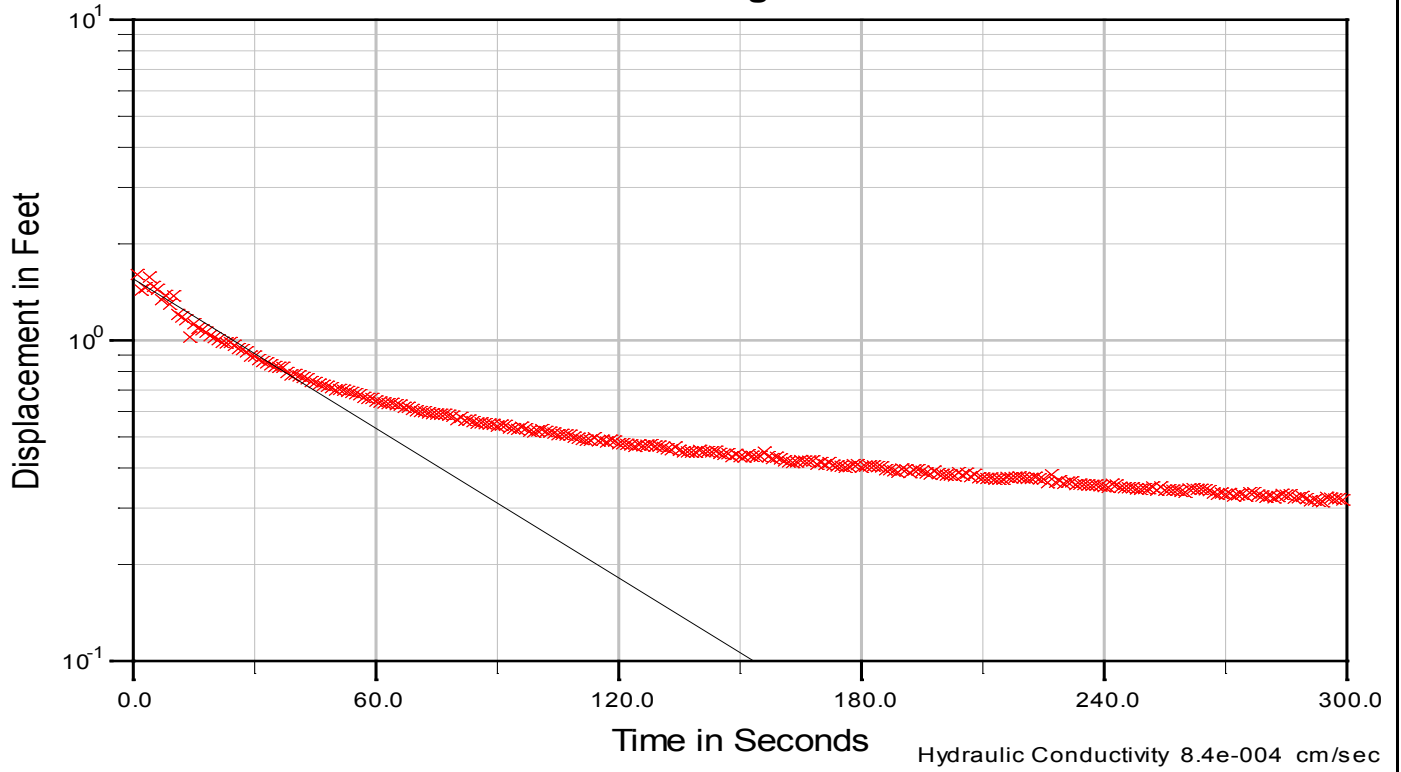

HC-2 Rising Head #1

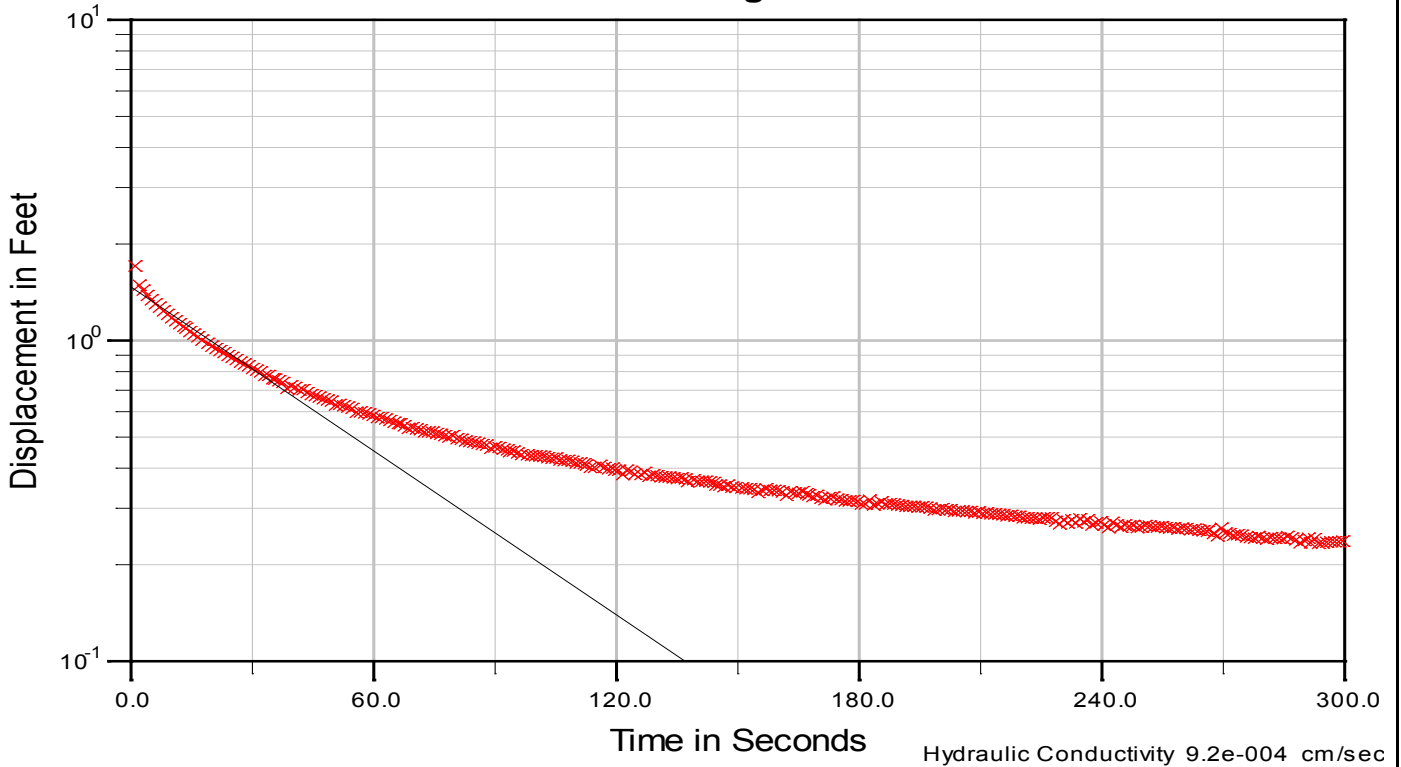

A:\JG 12/11/14 L:\Project Notebook\1798401 Mercer Island Multi family\Slug-test Files\Slug Test

Note:
Bouwer and Rice method was used for the slug test analysis.

Mercer Island Multi-Family Development
Mercer Island, Washington

HC-2 Representative Slug Tests Results

17984-01

12/14



Figure

4

ABPB-M3 - Falling Head #1

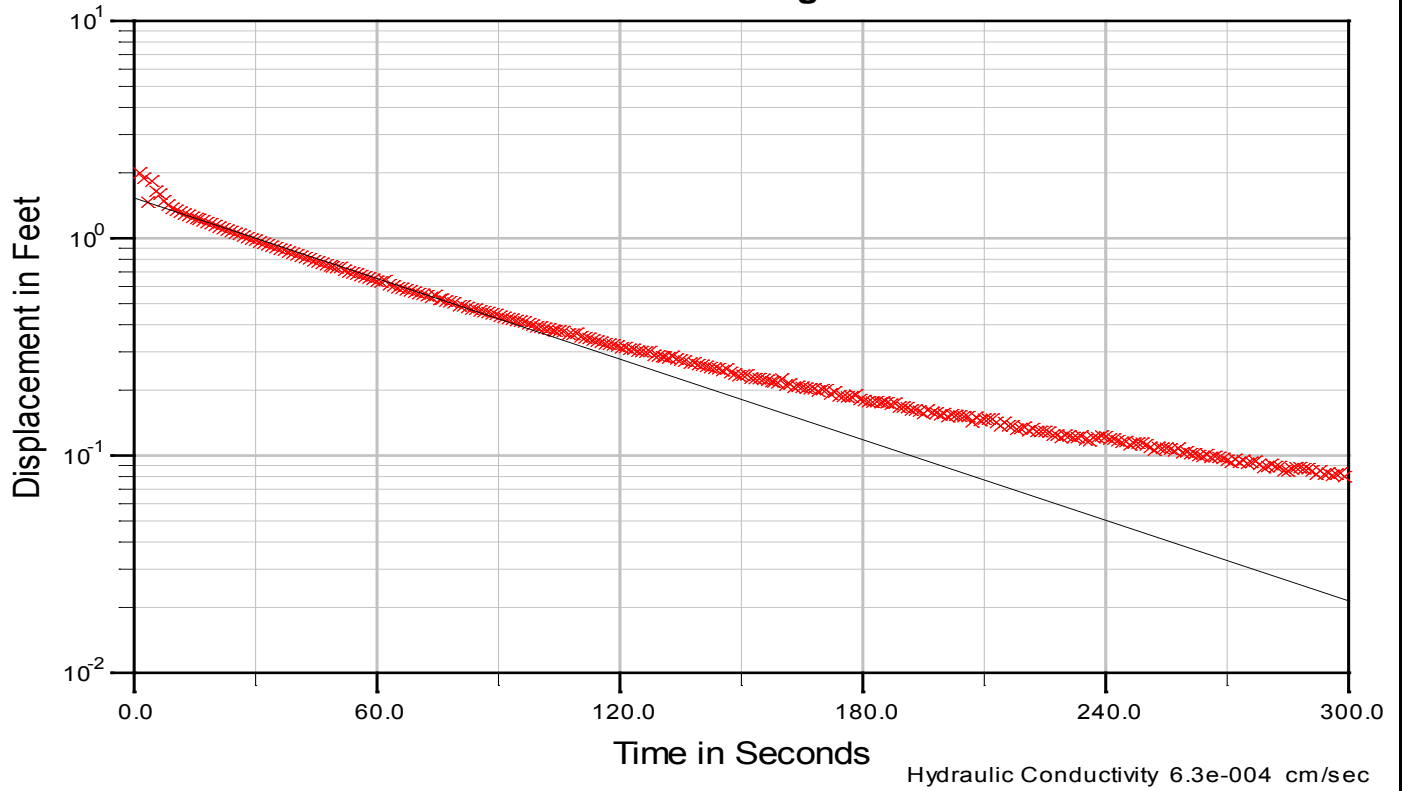

ABPB-M3 Rising Head #1

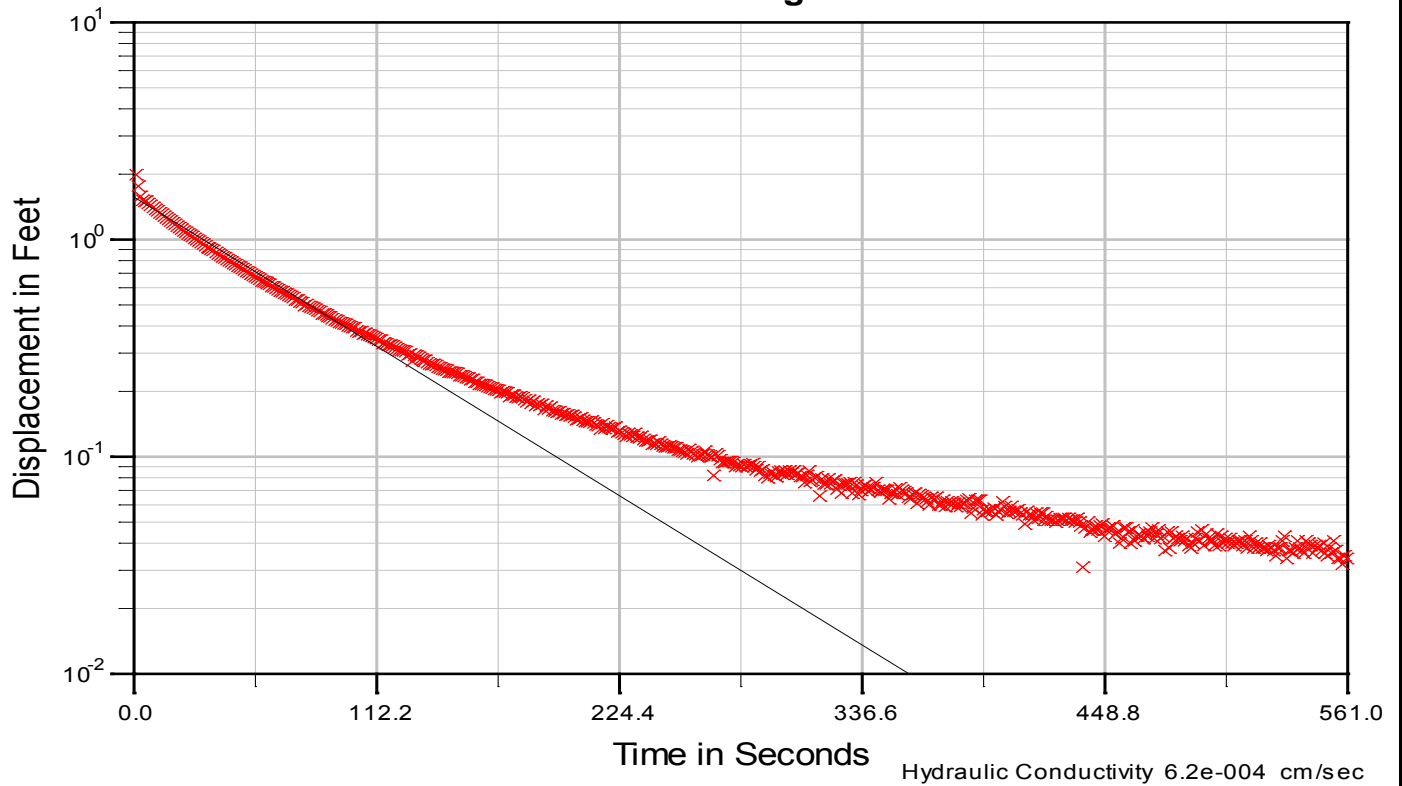

AUG 12/11/14 L:\Project Notebook\1798401 Mercer Island Multi family\Slug-test-Files\Slug Test

Note:
Bouwer and Rice method was used for the slug test analysis.

Mercer Island Multi-Family Development
Mercer Island, Washington

ABPB-M3 Representative Slug Tests Results

17984-01

12/14



Figure

5

Terra-B1 Falling Head #1

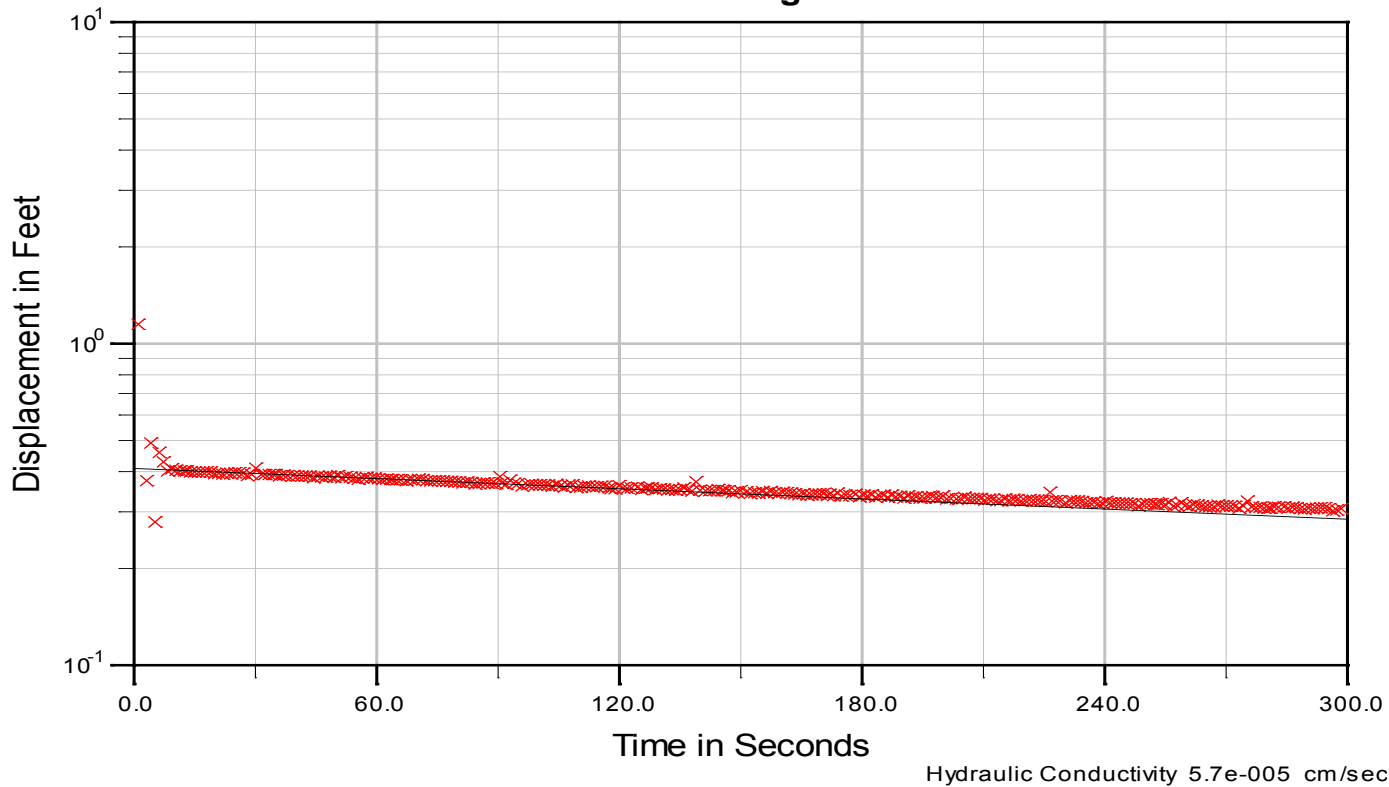

Terra-B1 Rising Head #1

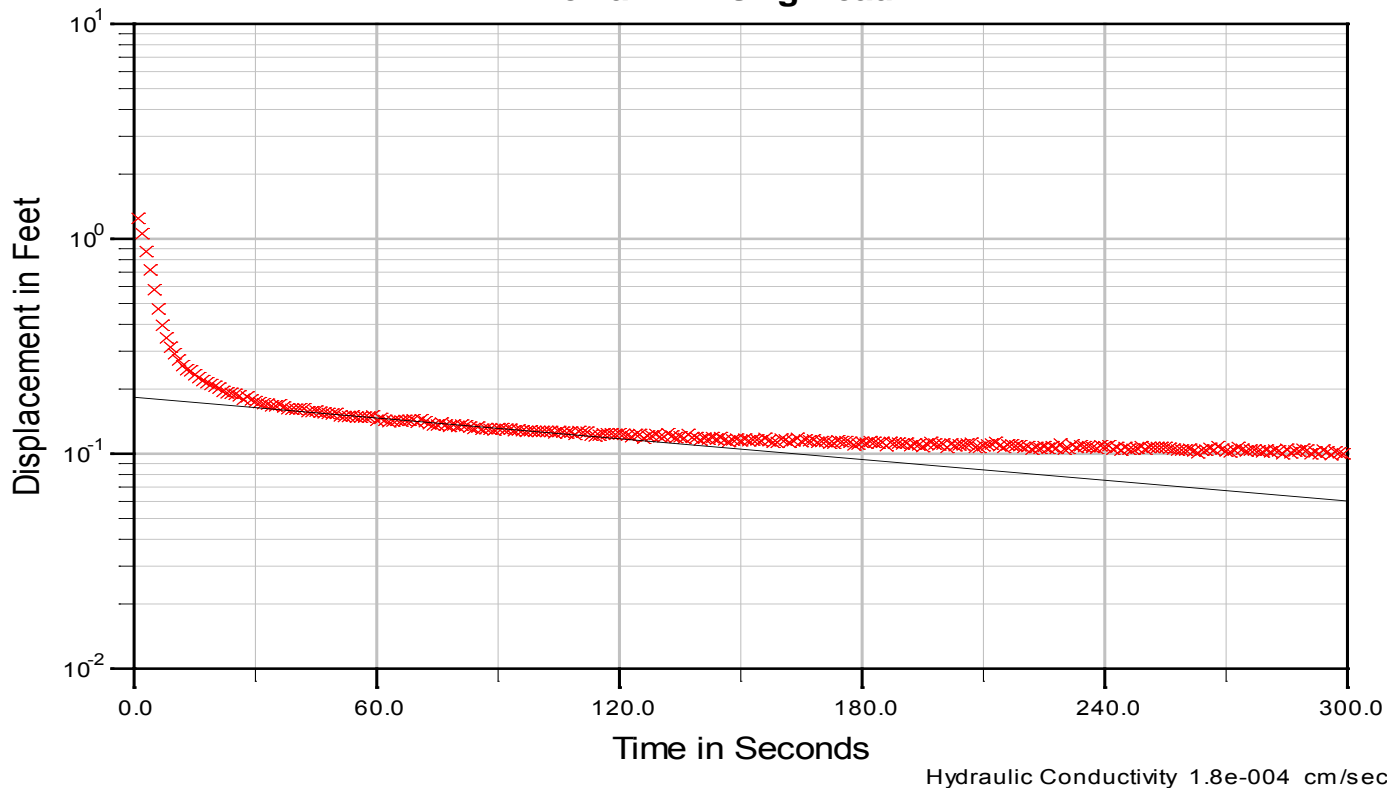

A:\J 12/11/14 L:\Project Notebook\1798401 Mercer Island Multi family\Slug-test-Files\Slug Test

Note:

Bouwer and Rice method was used for the slug test analysis.

Mercer Island Multi-Family Development
Mercer Island, Washington

Terra-B1 Representative Slug Tests Results

17984-01

12/14



Figure

6

APPENDIX A

Field Exploration Methods and Analysis

APPENDIX A

Field Exploration Methods and Analysis

This appendix documents the processes Hart Crowser used to determine the nature of the soils at the project site, and discusses:

- Explorations and their locations;
- Auger borings; and
- Standard Penetration Test procedures.

Explorations and Their Locations

The exploration logs in this appendix show our interpretation of the drilling, sampling, and testing data. These logs indicate the approximate depth where the soils change. Note that the soil changes may be gradual and may vary in depth across the site.

In the field, we classified the soil samples according to the methods shown on Figure A-1 - Key to Exploration Logs. This figure also provides a legend explaining the symbols and abbreviations used on the logs.

Explorations were located with a measuring tape from existing physical features. Elevations are referenced to the North American Vertical Datum of 1988 (NAVD88) and were estimated from the provided topographic survey.

Auger Borings

Borings were drilled with a 5.5-inch-inside-diameter, hollow-stem auger and were advanced with a truck-mounted drill rig subcontracted by Hart Crowser. The drilling was continuously observed by a geologist from Hart Crowser. A detailed field log was prepared for the boring. Using the Standard Penetration Test (SPT), we obtained samples at minimum 5-foot intervals.

Standard Penetration Test Procedures

The SPT is an approximate measure of soil density and consistency. To be useful, the results must be interpreted in conjunction with other tests. The SPT (as described in ASTM D 1586) was used to obtain disturbed soil samples.

This test employs a standard 2-inch-outside-diameter, split-spoon sampler. Using a 140-pound autohammer, free-falling 30 inches, the sampler is driven into the soil for 18 inches. The number of blows required to drive the sampler the last 12 inches is the Standard Penetration Resistance. This resistance, or blow count, measures the relative density of granular soils and the consistency of cohesive soils. The blow counts are plotted on the boring logs at their respective sample depths.

Soil samples were recovered from the split-spoon sampler, field classified, and placed into watertight jars. They were taken to Hart Crowser's laboratory for further testing.

In the Event of Hard Driving

Occasionally, very dense materials preclude driving the total 18-inch sample. When this happens, the penetration resistance is entered on logs as follows:

Penetration less than 6 inches. The log indicates the total number of blows over the number of inches of penetration.

Penetration greater than 6 inches. The blow count noted on the log is the sum of the total number of blows completed after the first 6 inches of penetration. This sum is expressed over the number of inches driven that exceed the first 6 inches. The number of blows needed to drive the first 6 inches are not reported. For example, a blow count series of 12 blows for 6 inches, 30 blows for 6 inches, and 50 (the maximum number of blows counted within a 6-inch increment for SPT) for 3 inches would be recorded as 80/9.

Monitoring Well Installation

After drilling, monitoring wells were installed in HC-1 and HC-2 for groundwater level monitoring and slug testing.

Two-inch-diameter Schedule 40 PVC riser pipe and two-inch-diameter 0.020-inch machine-slotted screen were used for the well casings and screens. The well screen and casing riser were lowered down through the open hole. Well seals were constructed by placing bentonite chips in the annular space on top of the filter sand to within 3 feet of the ground surface. The remaining annular space was backfilled with concrete to complete the surface seal. The monitoring well construction details are illustrated on the boring logs.

The monitoring wells were installed in accordance with Washington State Department of Ecology regulations.

Key to Exploration Logs

Sample Description

Classification of soils in this report is based on visual field and laboratory observations which include density/consistency, moisture condition, grain size, and plasticity estimates and should not be construed to imply field nor laboratory testing unless presented herein. Visual-manual classification methods of ASTM D 2488 were used as an identification guide.

Soil descriptions consist of the following:

Density/consistency, moisture, color, minor constituents, MAJOR CONSTITUENT, additional remarks.

Density/Consistency

Soil density/consistency in borings is related primarily to the Standard Penetration Resistance. Soil density/consistency in test pits and probes is estimated based on visual observation and is presented parenthetically on the logs.

SAND or GRAVEL Density	Standard Penetration Resistance (N) in Blows/Foot	SILT or CLAY Consistency	Standard Penetration Resistance (N) in Blows/Foot	Approximate Shear Strength in TSF
Very loose	0 to 4	Very soft	0 to 2	<0.125
Loose	4 to 10	Soft	2 to 4	0.125 to 0.25
Medium dense	10 to 30	Medium stiff	4 to 8	0.25 to 0.5
Dense	30 to 50	Stiff	8 to 15	0.5 to 1.0
Very dense	>50	Very stiff	15 to 30	1.0 to 2.0
		Hard	>30	>2.0

Sampling Test Symbols

1.5" I.D. Split Spoon	Grab (Jar)	3.0" I.D. Split Spoon
Shelby Tube (Pushed)	Bag	
Cuttings	Core Run	

SOIL CLASSIFICATION CHART

MAJOR DIVISIONS			SYMBOLS		TYPICAL DESCRIPTIONS	
			GRAPH	LETTER		
COARSE GRAINED SOILS MORE THAN 50% OF MATERIAL IS LARGER THAN NO. 200 SIEVE SIZE	GRAVEL AND GRAVELLY SOILS	CLEAN GRAVELS (LITTLE OR NO FINES)		GW	WELL-GRADED GRAVELS, GRAVEL - SAND MIXTURES, LITTLE OR NO FINES	
		GRAVELS WITH FINES (APPRECIABLE AMOUNT OF FINES)		GP	POORLY-GRADED GRAVELS, GRAVEL - SAND MIXTURES, LITTLE OR NO FINES	
	SAND AND SANDY SOILS	CLEAN SANDS (LITTLE OR NO FINES)		SW	WELL-GRADED SANDS, GRAVELLY SANDS, LITTLE OR NO FINES	
		SANDS WITH FINES (APPRECIABLE AMOUNT OF FINES)		SM	POORLY-GRADED SANDS, GRAVELLY SAND, LITTLE OR NO FINES	
	FINE GRAINED SOILS MORE THAN 50% OF MATERIAL IS SMALLER THAN NO. 200 SIEVE SIZE	SILTS AND CLAYS	LIQUID LIMIT LESS THAN 50		ML	INORGANIC SILTS AND VERY FINE SANDS, ROCK FLOUR, SILTY OR CLAYEY FINE SANDS OR CLAYEY SILTS WITH SLIGHT PLASTICITY
					CL	INORGANIC CLAYS OF LOW TO MEDIUM PLASTICITY, GRAVELLY CLAYS, SANDY CLAYS, SILTY CLAYS, LEAN CLAYS
				OL	ORGANIC SILTS AND ORGANIC SILTY CLAYS OF LOW PLASTICITY	
SILTS AND CLAYS	LIQUID LIMIT GREATER THAN 50		MH	INORGANIC SILTS, MICACEOUS OR DIATOMACEOUS FINE SAND OR SILTY SOILS		
			CH	INORGANIC CLAYS OF HIGH PLASTICITY		
			OH	ORGANIC CLAYS OF MEDIUM TO HIGH PLASTICITY, ORGANIC SILTS		
HIGHLY ORGANIC SOILS				PT	PEAT, HUMUS, SWAMP SOILS WITH HIGH ORGANIC CONTENTS	

NOTE: DUAL SYMBOLS ARE USED TO INDICATE BORDERLINE SOIL CLASSIFICATIONS

Moisture

Dry	Little perceptible moisture
Damp	Some perceptible moisture, likely below optimum
Moist	Likely near optimum moisture content
Wet	Much perceptible moisture, likely above optimum

Minor Constituents

Estimated Percentage

Trace	<5
Slightly (clayey, silty, etc.)	5 - 12
Clayey, silty, sandy, gravelly	12 - 30
Very (clayey, silty, etc.)	30 - 50

Laboratory Test Symbols

GS	Grain Size Classification
CN	Consolidation
UU	Unconsolidated Undrained Triaxial
CU	Consolidated Undrained Triaxial
CD	Consolidated Drained Triaxial
QU	Unconfined Compression
DS	Direct Shear
K	Permeability
PP	Pocket Penetrometer
	Approximate Compressive Strength in TSF
TV	Torvane
	Approximate Shear Strength in TSF
CBR	California Bearing Ratio
MD	Moisture Density Relationship
AL	Atterberg Limits
	Water Content in Percent
	Liquid Limit
	Natural Plastic Limit
PID	Photoionization Detector Reading
CA	Chemical Analysis
DT	In Situ Density in PCF
OT	Tests by Others

Groundwater Indicators

	Groundwater Level on Date or (ATD) At Time of Drilling
	Groundwater Seepage (Test Pits)

Sample Key

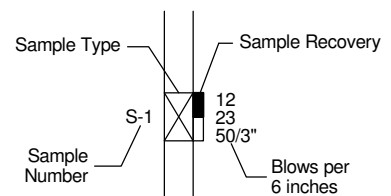

HARTCROWSER

17984-01

11/14

Figure A-1

Boring Log HC-1

Location: 47.584459, -122.234890
 Approximate Ground Surface Elevation: 83 Feet
 Horizontal Datum: WGS84
 Vertical Datum: NAVD88

Drill Equipment: HSA (Diedrich D50)
 Hammer Type: Auto-Trip
 Hole Diameter: 8 inches
 Logged By: M. Smith Reviewed By: M. Veenstra

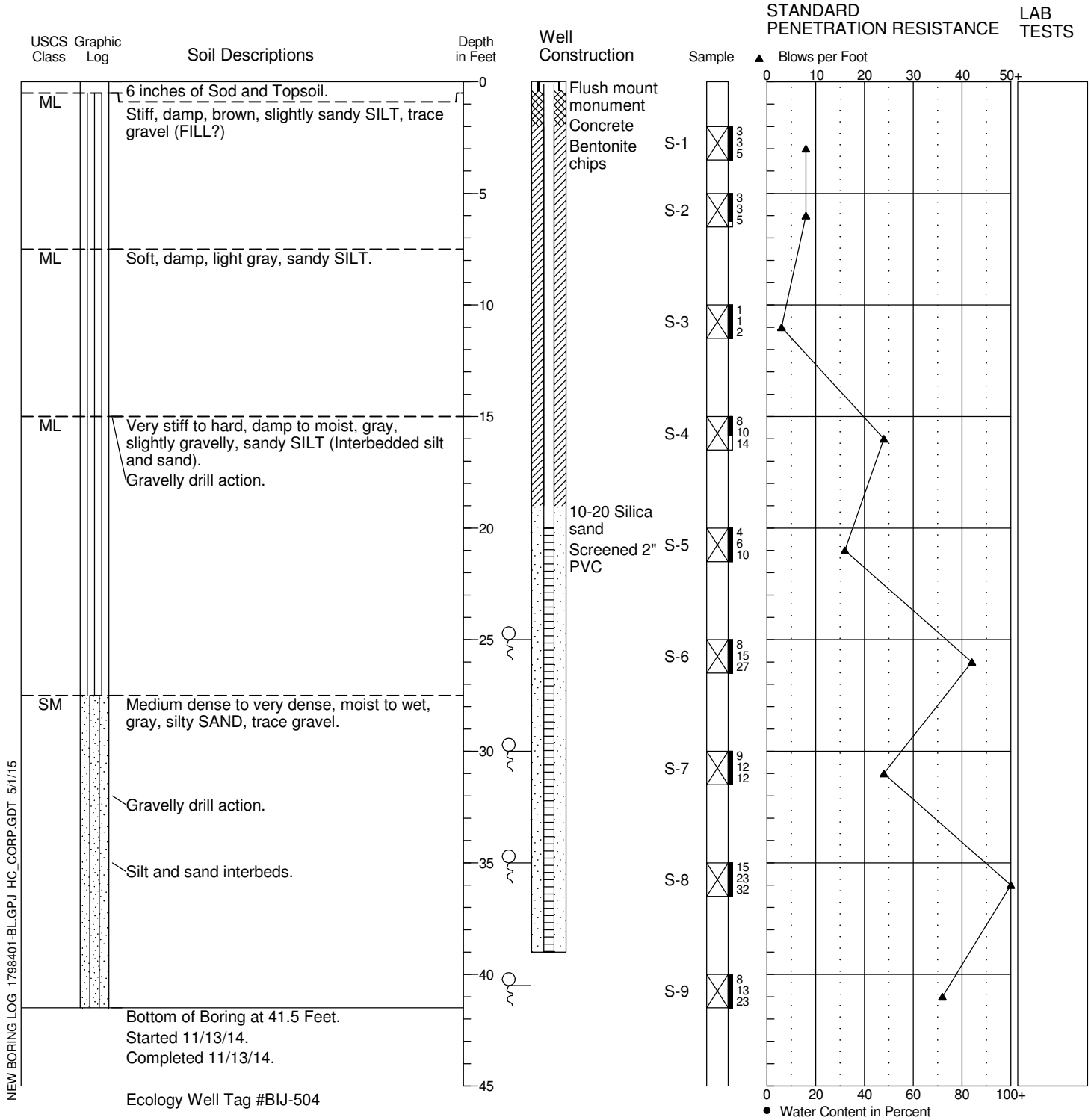

1. Refer to Figure A-1 for explanation of descriptions and symbols.
2. Soil descriptions and stratum lines are interpretive and actual changes may be gradual.
3. USCS designations are based on visual manual classification (ASTM D 2488) unless otherwise supported by laboratory testing (ASTM D 2487).
4. Groundwater level, if indicated, is at time of drilling (ATD) or for date specified. Level may vary with time.

Boring Log HC-2

Location: 47.584729, -122.234870
 Approximate Ground Surface Elevation: 83 Feet
 Horizontal Datum: WGS84
 Vertical Datum: NAVD88

Drill Equipment: HSA (Diedrich D50)
 Hammer Type: Auto-Trip
 Hole Diameter: 8 inches
 Logged By: M. Smith Reviewed By: M. Veenstra

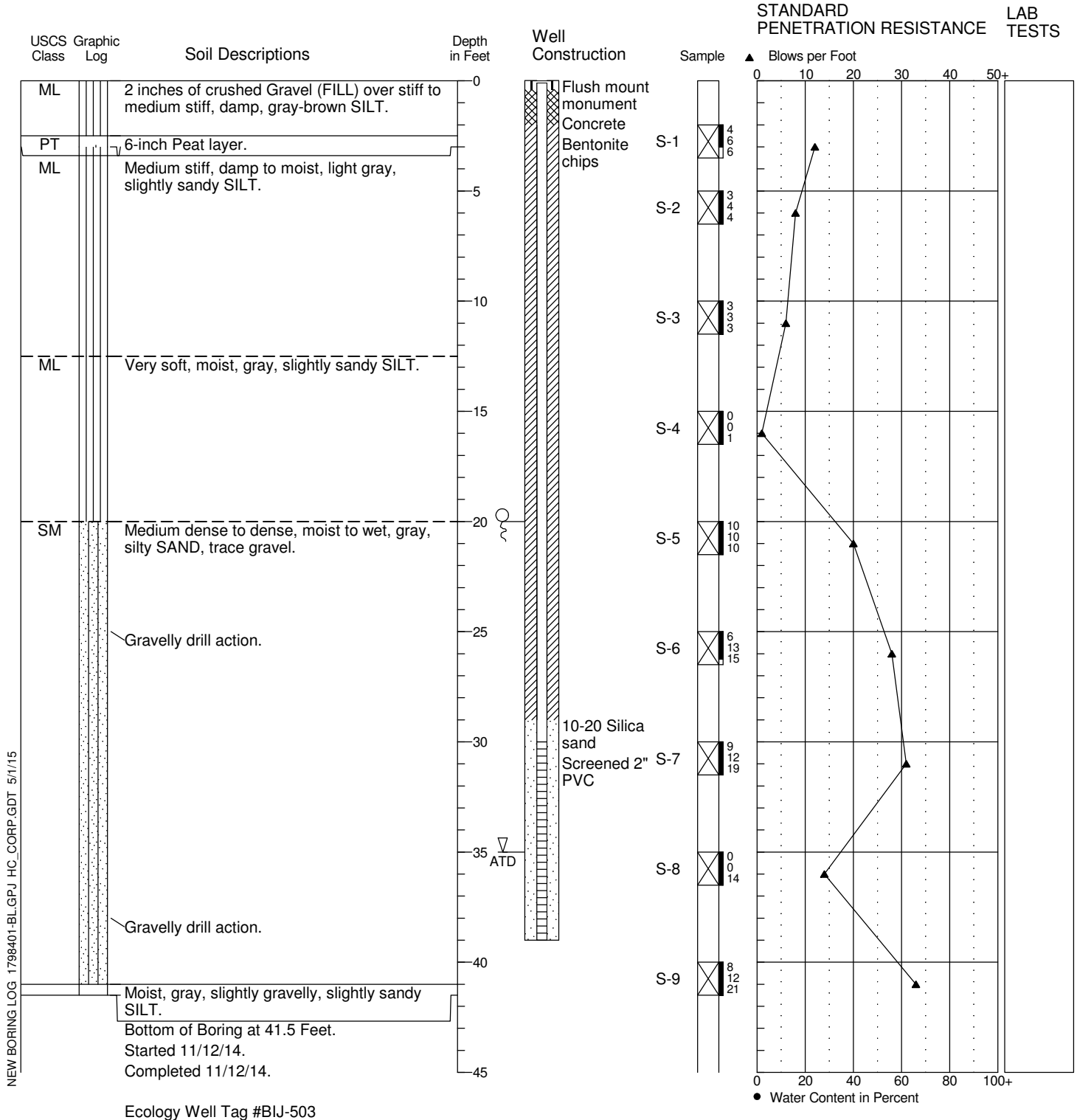

1. Refer to Figure A-1 for explanation of descriptions and symbols.
2. Soil descriptions and stratum lines are interpretive and actual changes may be gradual.
3. USCS designations are based on visual manual classification (ASTM D 2488) unless otherwise supported by laboratory testing (ASTM D 2487).
4. Groundwater level, if indicated, is at time of drilling (ATD) or for date specified. Level may vary with time.

Boring Log HC-3

Location: 47.585134, -122.234493
 Approximate Ground Surface Elevation: 83 Feet
 Horizontal Datum: WGS84
 Vertical Datum: NAVD88

Drill Equipment: HSA (Diedrich D50)
 Hammer Type: Auto-Trip
 Hole Diameter: 8 inches
 Logged By: M. Smith Reviewed By: M. Veenstra

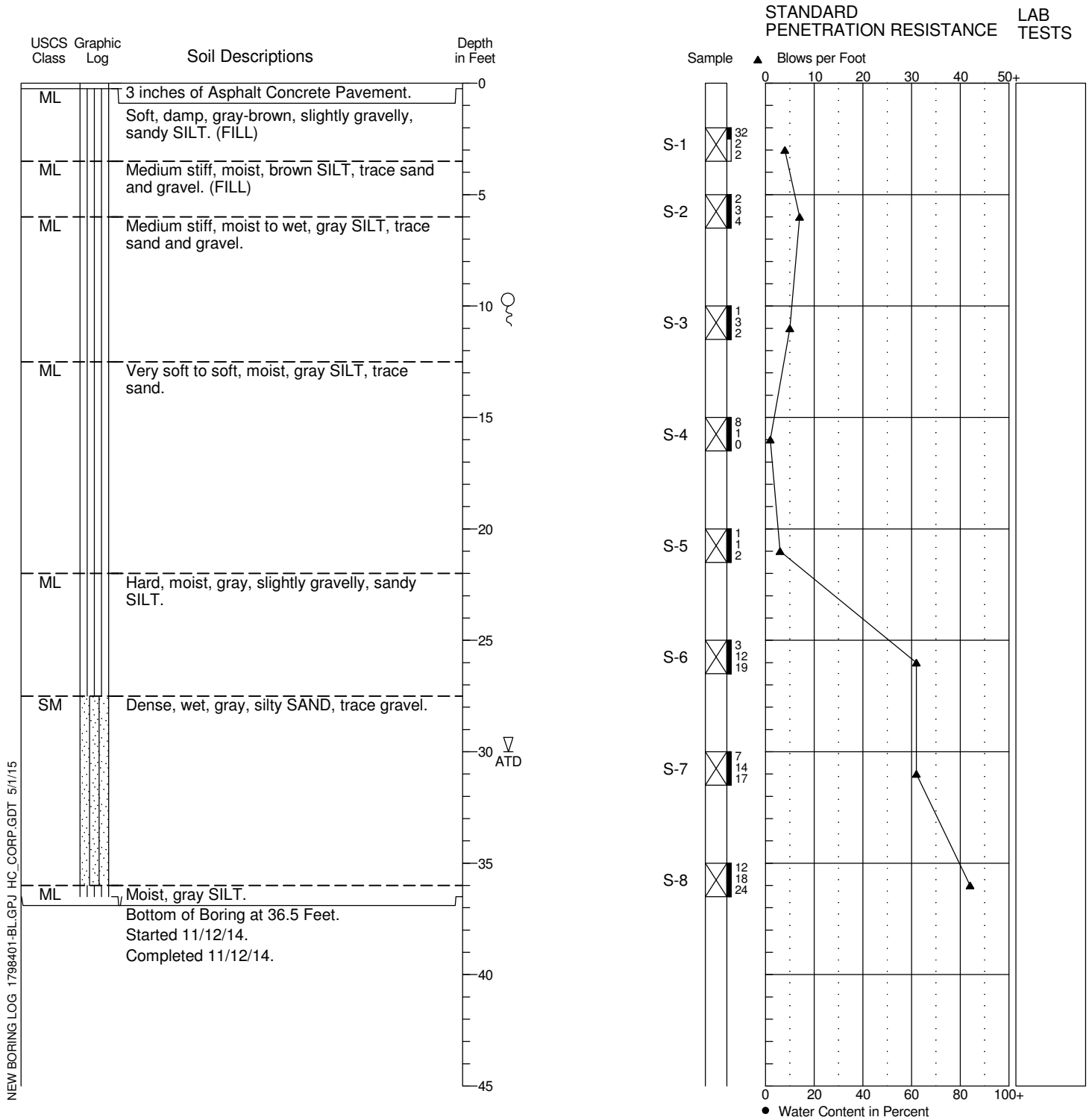

NEW BORING LOG 1798401-BL.GPJ HC_CORP.GDT 5/1/15

1. Refer to Figure A-1 for explanation of descriptions and symbols.
2. Soil descriptions and stratum lines are interpretive and actual changes may be gradual.
3. USCS designations are based on visual manual classification (ASTM D 2488) unless otherwise supported by laboratory testing (ASTM D 2487).
4. Groundwater level, if indicated, is at time of drilling (ATD) or for date specified. Level may vary with time.

Boring Log HC-4

Location: 47.585142, -122.233965
 Approximate Ground Surface Elevation: 88 Feet
 Horizontal Datum: WGS84
 Vertical Datum: NAVD88

Drill Equipment: HSA (Diedrich D50)
 Hammer Type: Auto-Trip
 Hole Diameter: 8 inches
 Logged By: M. Smith Reviewed By: M. Veenstra

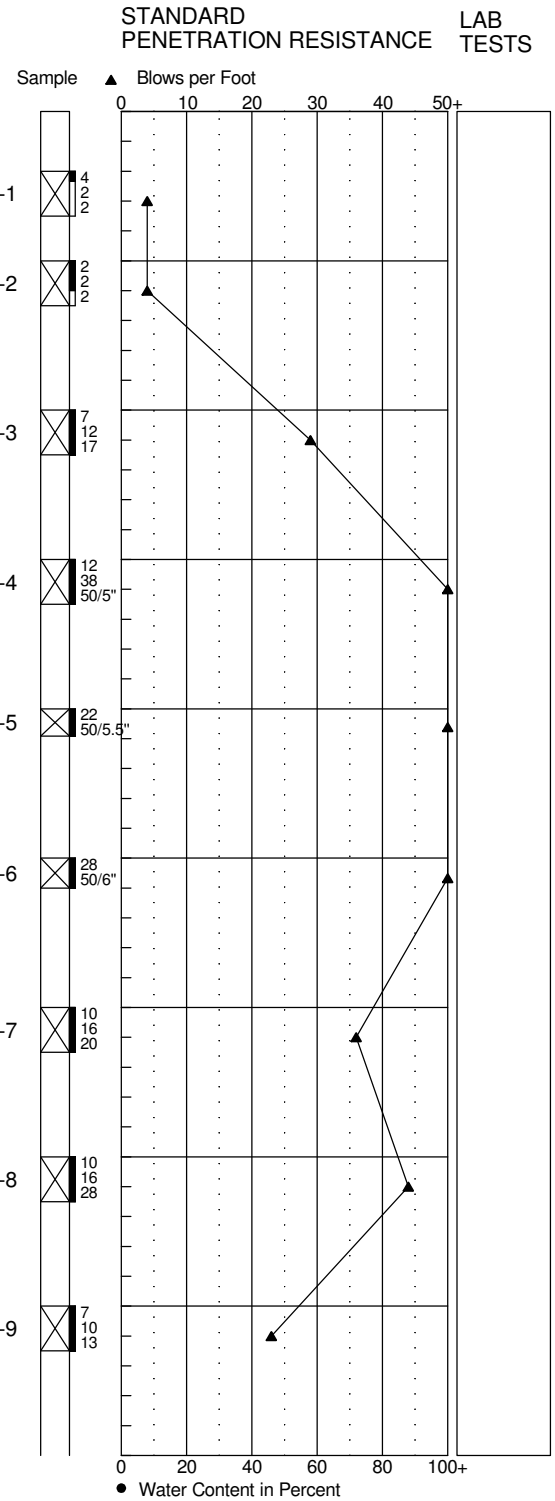
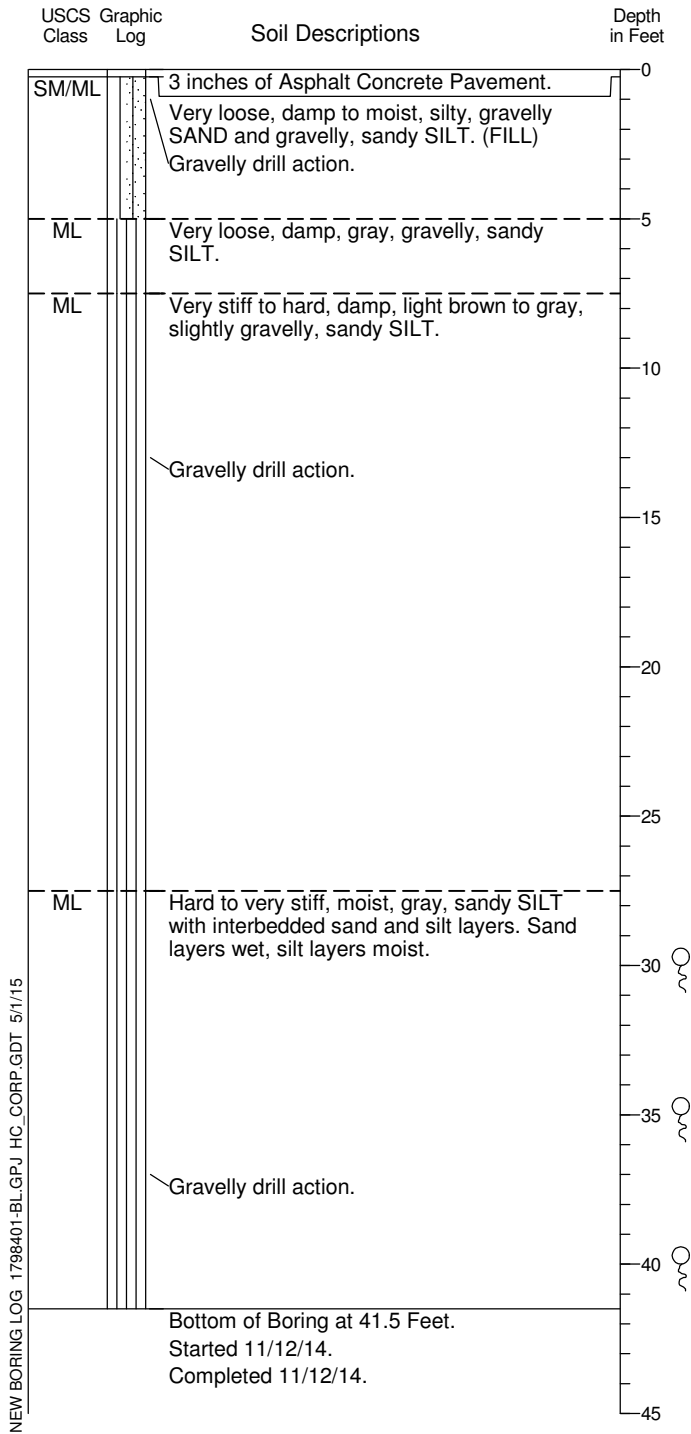

1. Refer to Figure A-1 for explanation of descriptions and symbols.
2. Soil descriptions and stratum lines are interpretive and actual changes may be gradual.
3. USCS designations are based on visual manual classification (ASTM D 2488) unless otherwise supported by laboratory testing (ASTM D 2487).
4. Groundwater level, if indicated, is at time of drilling (ATD) or for date specified. Level may vary with time.

Push Probe Log B-1

Location: Lat: 47.58453 Long: -122.2343
 Approximate Ground Surface Elevation: 82 Feet
 Horizontal Datum: WGS 84
 Vertical Datum: NAVD88

Drill Equipment: Push Probe
 Sample Type: Acetate Liner
 Hole Diameter: 2 inches
 Logged By: W. McDonald Reviewed By: M. Veenstra

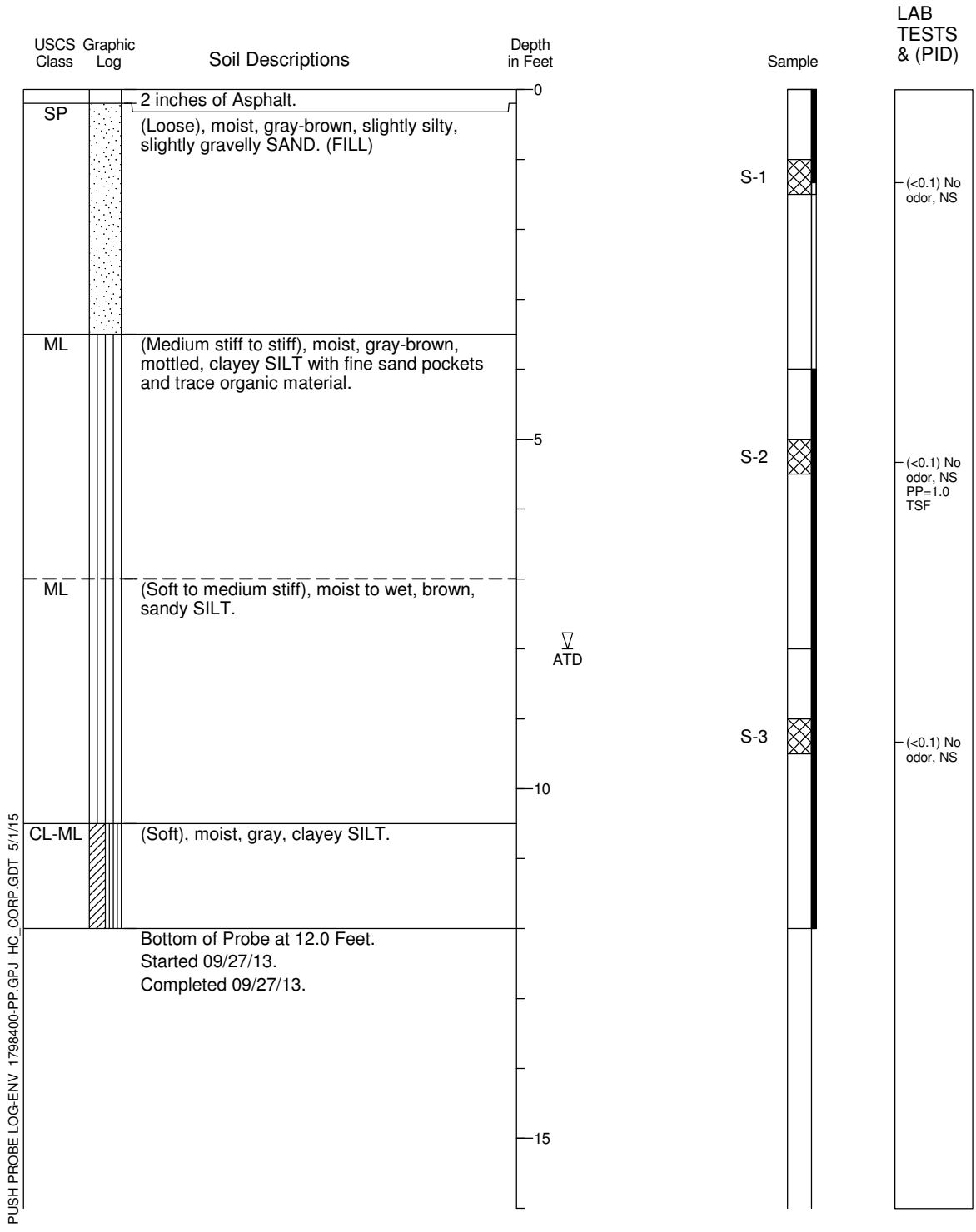

1. Refer to Figure A-1 for explanation of descriptions and symbols.
2. Soil descriptions and stratum lines are interpretive and actual changes may be gradual.
3. USCS designations are based on visual manual classification (ASTM D 2488) unless otherwise supported by laboratory testing (ASTM D 2487).
4. Groundwater level, if indicated, is at time of drilling (ATD) or for date specified. Level may vary with time.
5. NS = No Sheen; SS = Slight Sheen; MS = Moderate Sheen; HS = Heavy Sheen

Push Probe Log B-2

Location: Lat: 47.58454 Long: -122.2345
 Approximate Ground Surface Elevation: 82 Feet
 Horizontal Datum: WGS 84
 Vertical Datum: NAVD88

Drill Equipment: Push Probe
 Sample Type: Acetate Liner
 Hole Diameter: 2 inches
 Logged By: W. McDonald Reviewed By: M. Veenstra

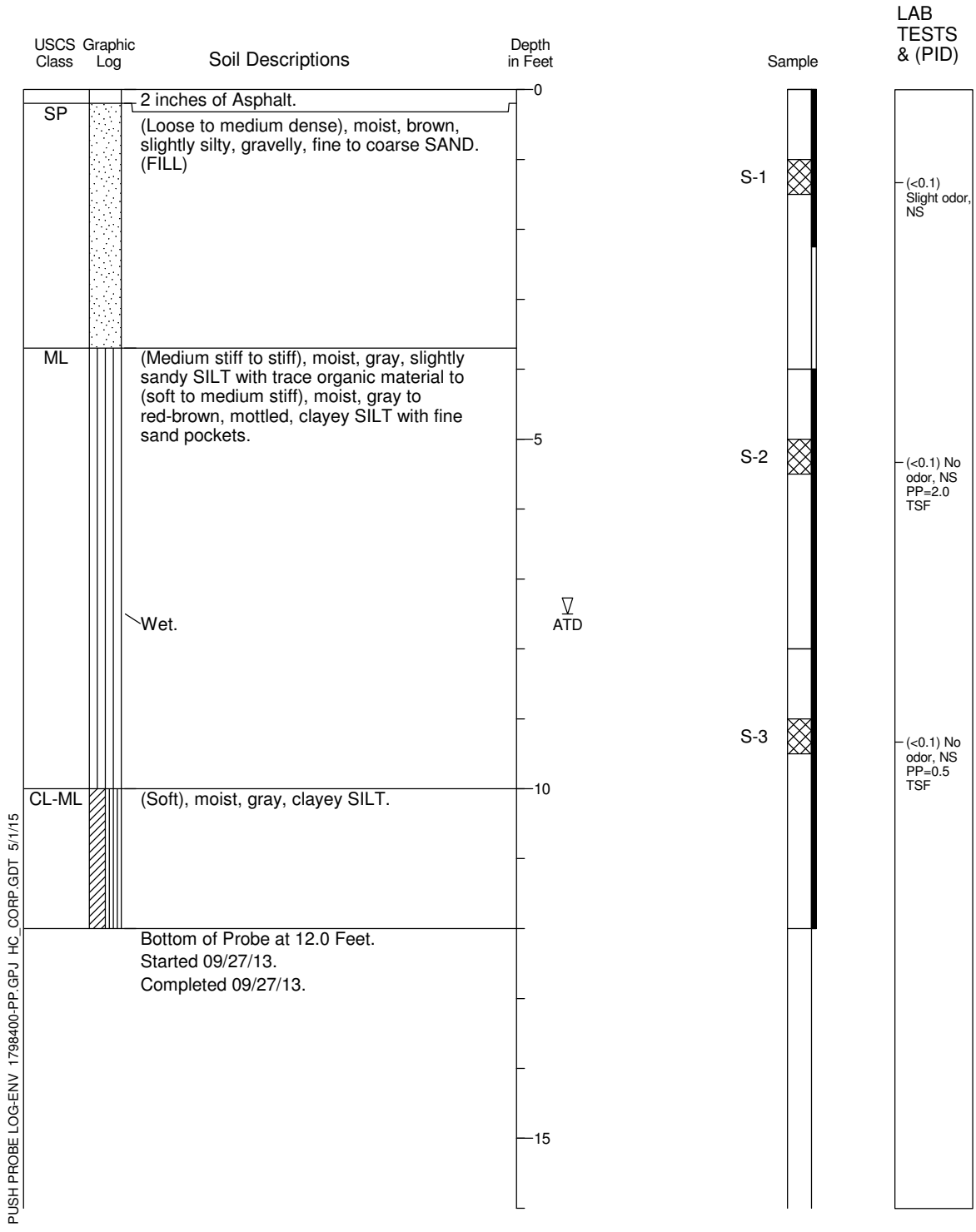

PUSH PROBE LOG-ENV 1798400-PP.GPJ HC_CORP.GDT 5/1/15

1. Refer to Figure A-1 for explanation of descriptions and symbols.
2. Soil descriptions and stratum lines are interpretive and actual changes may be gradual.
3. USCS designations are based on visual manual classification (ASTM D 2488) unless otherwise supported by laboratory testing (ASTM D 2487).
4. Groundwater level, if indicated, is at time of drilling (ATD) or for date specified. Level may vary with time.
5. NS = No Sheen; SS = Slight Sheen; MS = Moderate Sheen; HS = Heavy Sheen

Push Probe Log B-3

Location: Lat: 47.58477 Long: -122.2349
 Approximate Ground Surface Elevation: 84 Feet
 Horizontal Datum: WGS 84
 Vertical Datum: NAVD88

Drill Equipment: Push Probe
 Sample Type: Acetate Liner
 Hole Diameter: 2 inches
 Logged By: W. McDonald Reviewed By: M. Veenstra

LAB TESTS

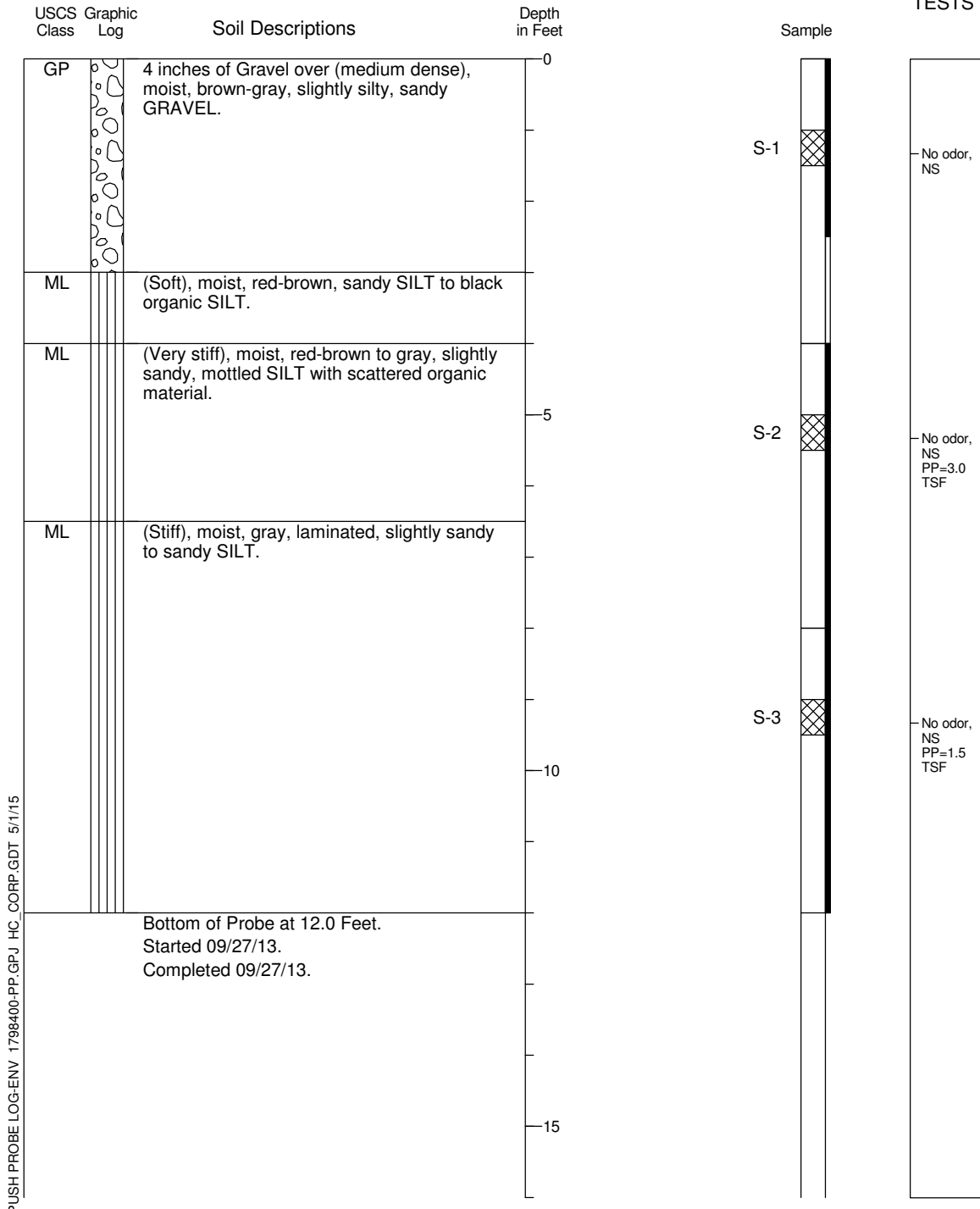

PUSH PROBE LOG-ENV 1798400-PP.GPJ HC_CORP.GDT 5/1/15

1. Refer to Figure A-1 for explanation of descriptions and symbols.
2. Soil descriptions and stratum lines are interpretive and actual changes may be gradual.
3. USCS designations are based on visual manual classification (ASTM D 2488) unless otherwise supported by laboratory testing (ASTM D 2487).
4. Groundwater level, if indicated, is at time of drilling (ATD) or for date specified. Level may vary with time.
5. NS = No Sheen; SS = Slight Sheen; MS = Moderate Sheen; HS = Heavy Sheen

Push Probe Log B-4

Location: Lat: 47.58468 Long: -122.2348
 Approximate Ground Surface Elevation: 84 Feet
 Horizontal Datum: WGS 84
 Vertical Datum: NAVD88

Drill Equipment: Push Probe
 Sample Type: Acetate Liner
 Hole Diameter: 2 inches
 Logged By: W. McDonald Reviewed By: M. Veenstra

LAB TESTS

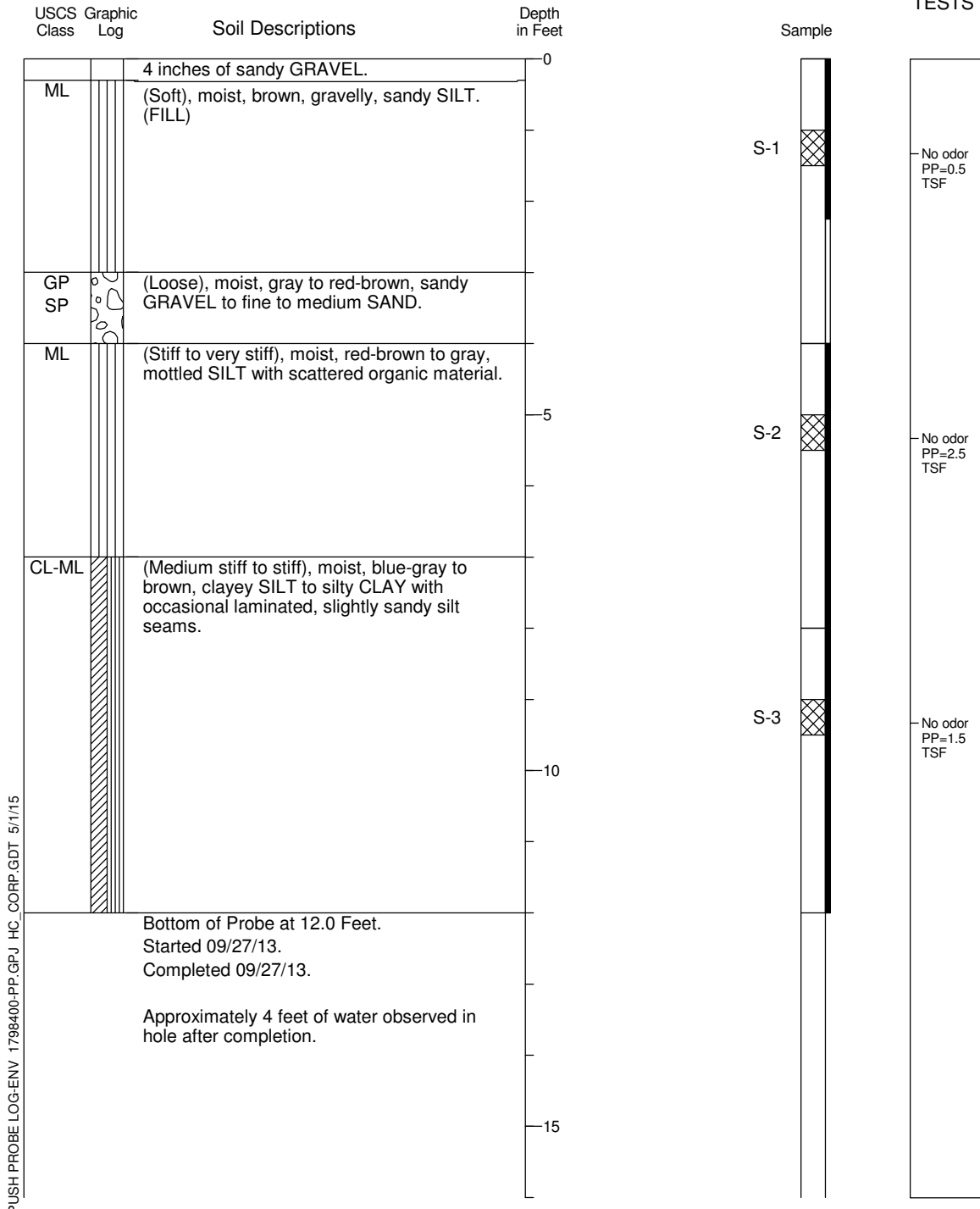

1. Refer to Figure A-1 for explanation of descriptions and symbols.
2. Soil descriptions and stratum lines are interpretive and actual changes may be gradual.
3. USCS designations are based on visual manual classification (ASTM D 2488) unless otherwise supported by laboratory testing (ASTM D 2487).
4. Groundwater level, if indicated, is at time of drilling (ATD) or for date specified. Level may vary with time.
5. NS = No Sheen; SS = Slight Sheen; MS = Moderate Sheen; HS = Heavy Sheen



HARTCROWSER

17984-00

9/13

Figure A-9

Push Probe Log B-5

Location: Lat: 47.5846 Long: -122.2346
 Approximate Ground Surface Elevation: 81 Feet
 Horizontal Datum: WGS 84
 Vertical Datum: NAVD88

Drill Equipment: Push Probe
 Sample Type: Acetate Liner
 Hole Diameter: 2 inches
 Logged By: W. McDonald Reviewed By: M. Veenstra

LAB TESTS

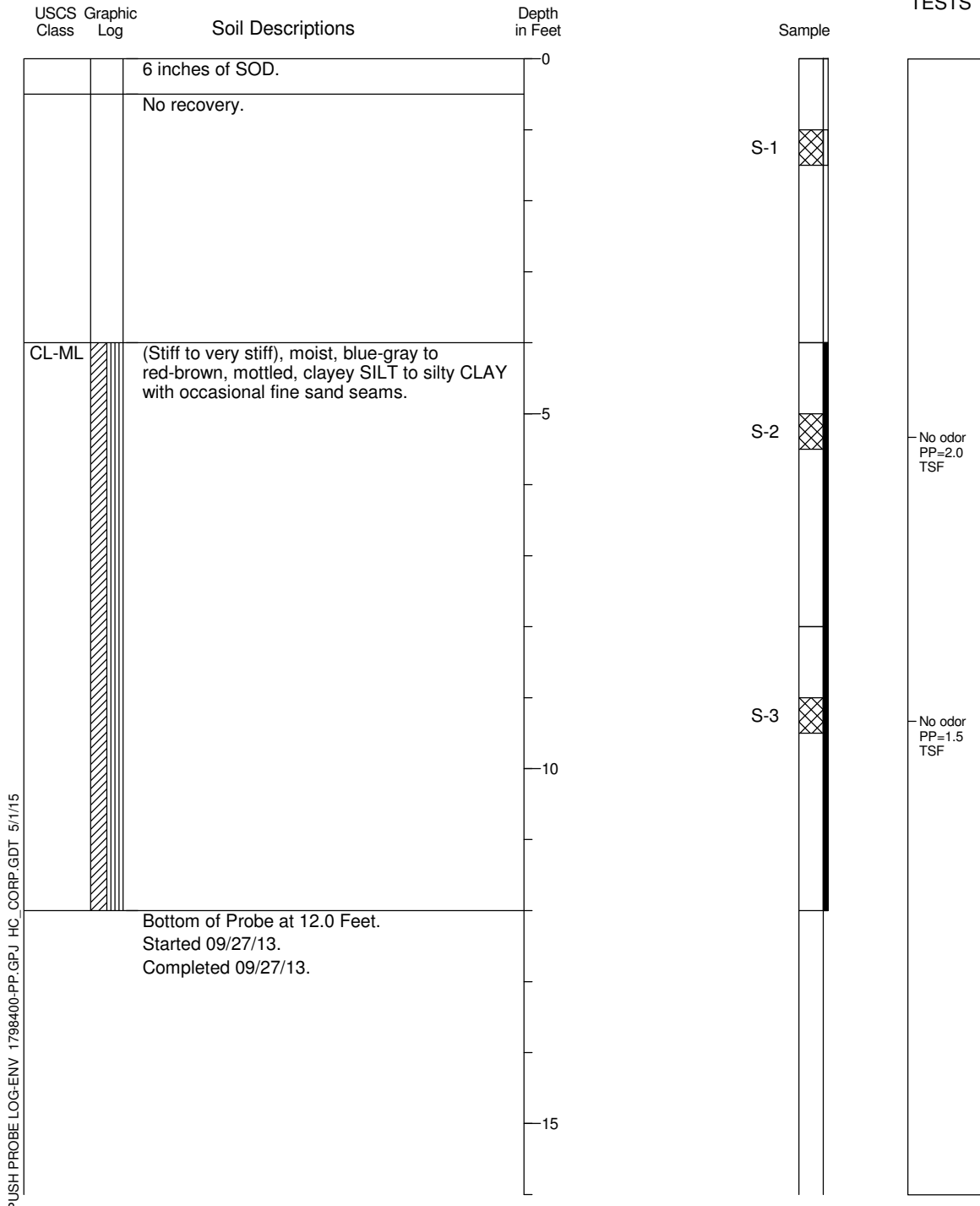

1. Refer to Figure A-1 for explanation of descriptions and symbols.
2. Soil descriptions and stratum lines are interpretive and actual changes may be gradual.
3. USCS designations are based on visual manual classification (ASTM D 2488) unless otherwise supported by laboratory testing (ASTM D 2487).
4. Groundwater level, if indicated, is at time of drilling (ATD) or for date specified. Level may vary with time.
5. NS = No Sheen; SS = Slight Sheen; MS = Moderate Sheen; HS = Heavy Sheen



HARTCROWSER

17984-00

9/13

Figure A-10

Push Probe Log B-6

Location: Lat: 47.58482 Long: -122.2345
 Approximate Ground Surface Elevation: 81 Feet
 Horizontal Datum: WGS 84
 Vertical Datum: NAVD88

Drill Equipment: Push Probe
 Sample Type: Acetate Liner
 Hole Diameter: 2 inches
 Logged By: W. McDonald Reviewed By: M. Veenstra

LAB TESTS

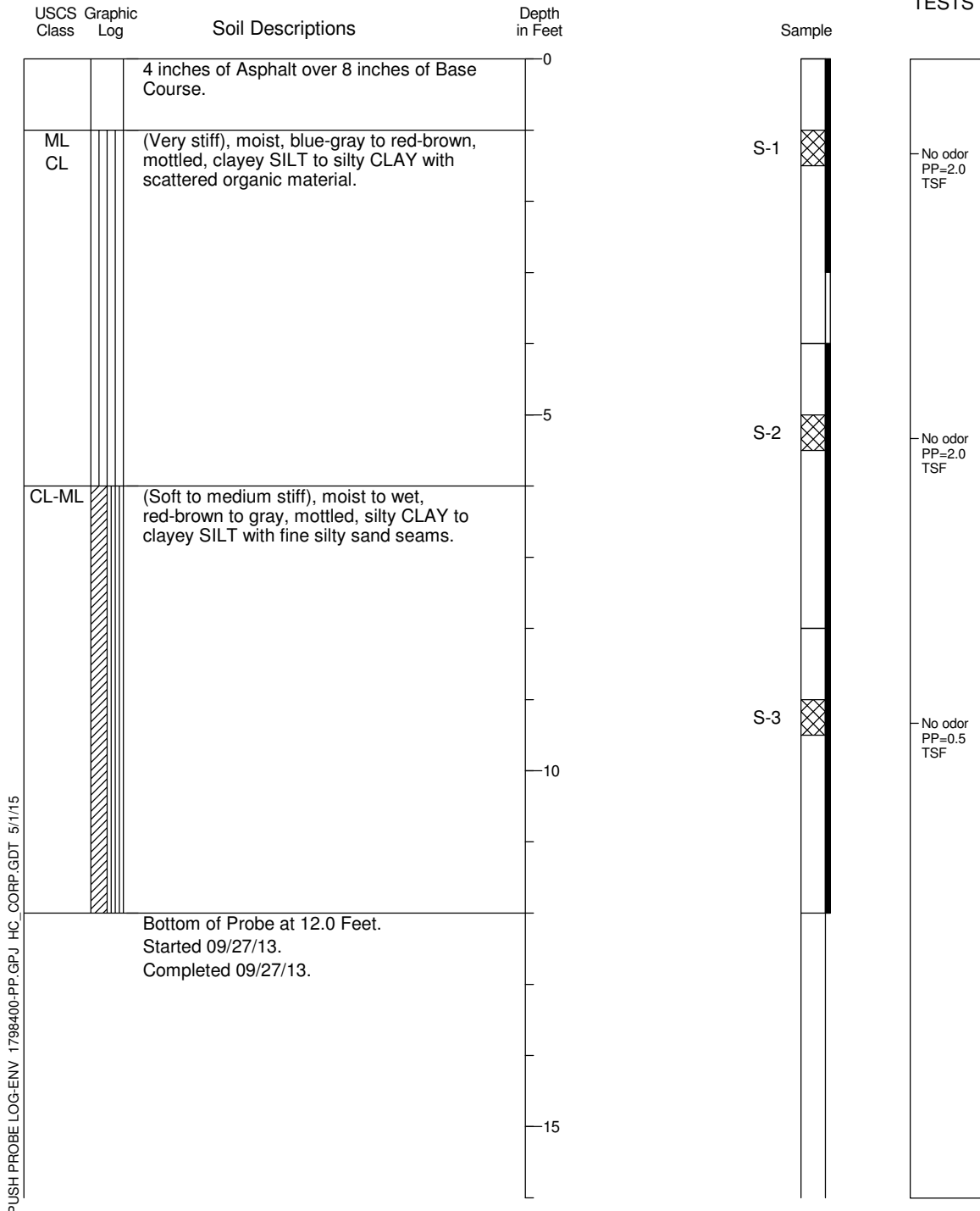

1. Refer to Figure A-1 for explanation of descriptions and symbols.
2. Soil descriptions and stratum lines are interpretive and actual changes may be gradual.
3. USCS designations are based on visual manual classification (ASTM D 2488) unless otherwise supported by laboratory testing (ASTM D 2487).
4. Groundwater level, if indicated, is at time of drilling (ATD) or for date specified. Level may vary with time.
5. NS = No Sheen; SS = Slight Sheen; MS = Moderate Sheen; HS = Heavy Sheen



HARTCROWSER

17984-00

9/13

Figure A-11

Push Probe Log B-7

Location: Lat: 47.58514 Long: -122.2342
 Approximate Ground Surface Elevation: 86 Feet
 Horizontal Datum: WGS 84
 Vertical Datum: NAVD88

Drill Equipment: Push Probe
 Sample Type: Acetate Liner
 Hole Diameter: 2 inches
 Logged By: W. McDonald Reviewed By: M. Veenstra

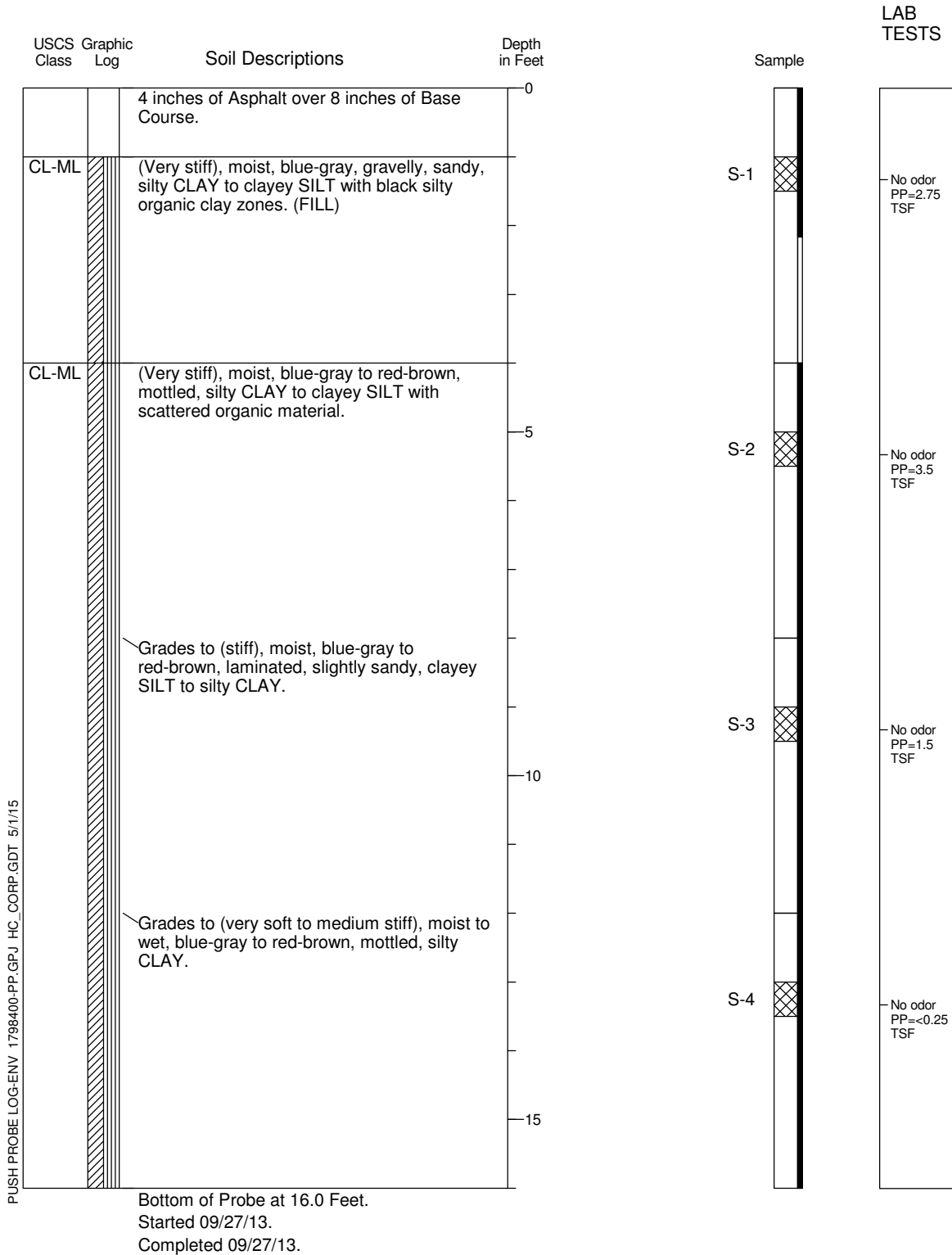

1. Refer to Figure A-1 for explanation of descriptions and symbols.
2. Soil descriptions and stratum lines are interpretive and actual changes may be gradual.
3. USCS designations are based on visual manual classification (ASTM D 2488) unless otherwise supported by laboratory testing (ASTM D 2487).
4. Groundwater level, if indicated, is at time of drilling (ATD) or for date specified. Level may vary with time.
5. NS = No Sheen; SS = Slight Sheen; MS = Moderate Sheen; HS = Heavy Sheen

Push Probe Log B-8

Location: Lat: 47.58477 Long: -122.2338
 Approximate Ground Surface Elevation: 92 Feet
 Horizontal Datum: WGS 84
 Vertical Datum: NAVD88

Drill Equipment: Push Probe
 Sample Type: Acetate Liner
 Hole Diameter: 2 inches
 Logged By: W. McDonald Reviewed By: M. Veenstra

LAB TESTS

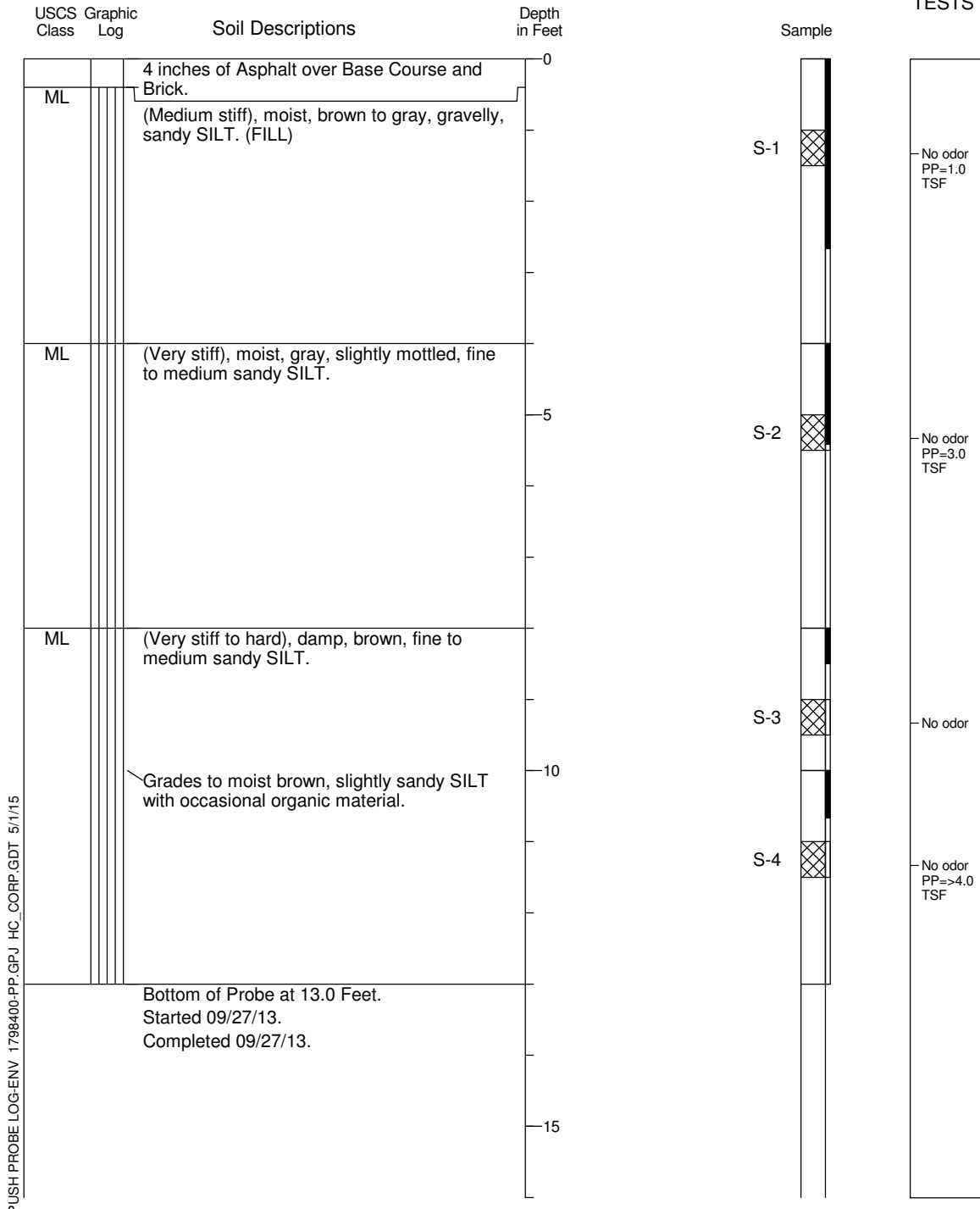

1. Refer to Figure A-1 for explanation of descriptions and symbols.
2. Soil descriptions and stratum lines are interpretive and actual changes may be gradual.
3. USCS designations are based on visual manual classification (ASTM D 2488) unless otherwise supported by laboratory testing (ASTM D 2487).
4. Groundwater level, if indicated, is at time of drilling (ATD) or for date specified. Level may vary with time.
5. NS = No Sheen; SS = Slight Sheen; MS = Moderate Sheen; HS = Heavy Sheen



HARTCROWSER

17984-00

9/13

Figure A-13

WILDCAT DYNAMIC CONE LOG

Hart Crowser
1700 Westlake Ave N.
Seattle, WA 98109

PROJECT NUMBER: 1798401
DATE STARTED: 11-20-2014
DATE COMPLETED: 11-20-2014

HOLE #: HC-5
CREW: Jesse Overton
PROJECT: Mercer Island Multi-Family
ADDRESS: _____
LOCATION: Mercer Island, Washington

SURFACE ELEVATION: _____
WATER ON COMPLETION: _____
HAMMER WEIGHT: 35 lbs.
CONE AREA: 10 sq. cm

DEPTH	BLOWS PER 10 cm	RESISTANCE Kg/cm ²	GRAPH OF CONE RESISTANCE 0 50 100 150	N'	TESTED CONSISTENCY	
					NON-COHESIVE	COHESIVE
-	18	79.9	22	MEDIUM DENSE	VERY STIFF
-	23	102.1	25+	MEDIUM DENSE	VERY STIFF
- 1 ft	14	62.2	17	MEDIUM DENSE	VERY STIFF
-	12	53.3	15	MEDIUM DENSE	STIFF
-	10	44.4	12	MEDIUM DENSE	STIFF
- 2 ft	9	40.0	11	MEDIUM DENSE	STIFF
-	9	40.0	11	MEDIUM DENSE	STIFF
-	10	44.4	12	MEDIUM DENSE	STIFF
- 3 ft	14	62.2	17	MEDIUM DENSE	VERY STIFF
- 1 m	9	40.0	11	MEDIUM DENSE	STIFF
-	11	42.5	12	MEDIUM DENSE	STIFF
- 4 ft	11	42.5	12	MEDIUM DENSE	STIFF
-	11	42.5	12	MEDIUM DENSE	STIFF
-	10	38.6	11	MEDIUM DENSE	STIFF
- 5 ft	8	30.9	8	LOOSE	MEDIUM STIFF
-	6	23.2	6	LOOSE	MEDIUM STIFF
-	6	23.2	6	LOOSE	MEDIUM STIFF
- 6 ft	7	27.0	7	LOOSE	MEDIUM STIFF
-	6	23.2	6	LOOSE	MEDIUM STIFF
- 2 m	6	23.2	6	LOOSE	MEDIUM STIFF
- 7 ft	6	20.5	5	LOOSE	MEDIUM STIFF
-	6	20.5	5	LOOSE	MEDIUM STIFF
-	5	17.1	4	VERY LOOSE	SOFT
- 8 ft	6	20.5	5	LOOSE	MEDIUM STIFF
-	5	17.1	4	VERY LOOSE	SOFT
-	5	17.1	4	VERY LOOSE	SOFT
- 9 ft	6	20.5	5	LOOSE	MEDIUM STIFF
-	6	20.5	5	LOOSE	MEDIUM STIFF
-	6	20.5	5	LOOSE	MEDIUM STIFF
- 3 m 10 ft	6	20.5	5	LOOSE	MEDIUM STIFF
-	6	18.4	5	LOOSE	MEDIUM STIFF
-	6	18.4	5	LOOSE	MEDIUM STIFF
-	12	36.7	10	LOOSE	STIFF
- 11 ft	9	27.5	7	LOOSE	MEDIUM STIFF
-	6	18.4	5	LOOSE	MEDIUM STIFF
-	7	21.4	6	LOOSE	MEDIUM STIFF
- 12 ft	4	12.2	...	3	VERY LOOSE	SOFT
-	5	15.3	4	VERY LOOSE	SOFT
-	6	18.4	5	LOOSE	MEDIUM STIFF
- 4 m 13 ft	6	18.4	5	LOOSE	MEDIUM STIFF

APPENDIX B

Historical Explorations

APPENDIX B

Historical Explorations

Historical exploration logs are included in this appendix as follows:

Terra 2012. Preliminary Geotechnical Report, Mercer Island North, 2885 - 78th Avenue SE, Mercer Island, Washington. May 10, 2012. Project No. T-6714.

ABPB 2012. Preliminary Geotechnical Report, Multifamily Residential Project, 2885 - 78th Avenue SE, Mercer Island, Washington. October 23, 2012. Project No. 1350.

Logs and test reports by others are included as they were produced by others for reference only and Hart Crowser is not responsible for the accuracy or completeness of the information presented in the logs. Approximate locations of the explorations by others are shown on Figure 2 of this report; actual locations may differ from those shown.

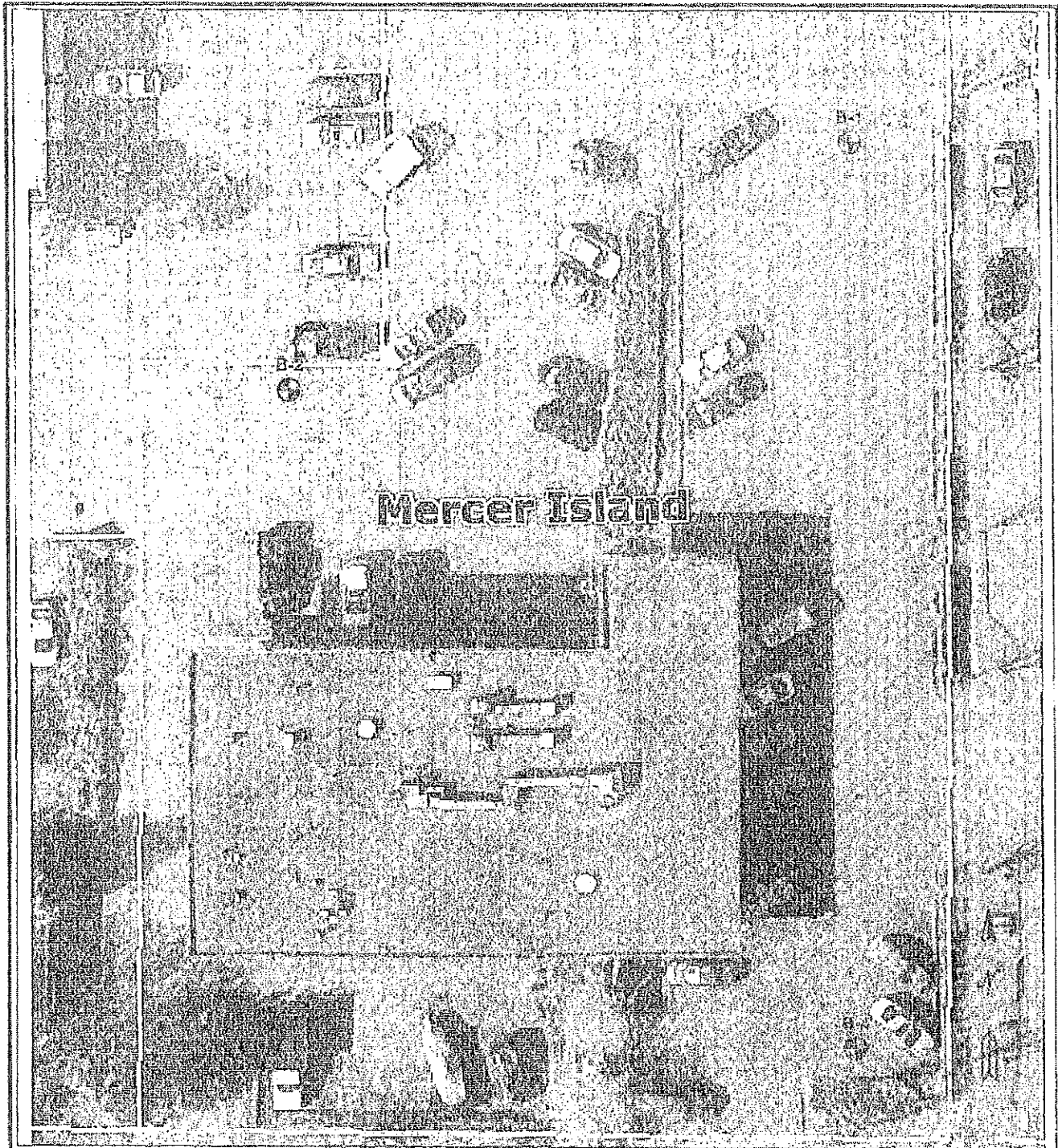

NOTE:

THIS SITE PLAN IS SCHEMATIC. ALL LOCATIONS AND DIMENSIONS ARE APPROXIMATE. IT IS INTENDED FOR REFERENCE ONLY AND SHOULD NOT BE USED FOR DESIGN OR CONSTRUCTION PURPOSES.

LEGEND:

⊕ APPROXIMATE BORING LOCATION

REFERENCE:

SITE PLAN PROVIDED BY KING COUNTY IMAP



Terra Associates, Inc.
 Consultants in Geotechnical Engineering
 Geology and
 Environmental Earth Sciences

**EXPLORATION LOCATION PLAN
 MERCER ISLAND NORTH
 MERCER ISLAND, WASHINGTON**

Proj. No. T-6714

Date MAY 2012

Figure 2

MAJOR DIVISIONS			LETTER SYMBOL	TYPICAL DESCRIPTION
COARSE GRAINED SOILS More than 50% material larger than No. 200 sieve size	GRAVELS More than 50% of coarse fraction is larger than No. 4 sieve	Clean Gravels (less than 5% fines)	GW	Well-graded gravels, gravel-sand mixtures, little or no fines.
		Gravels with fines	GP	Poorly-graded gravels, gravel-sand mixtures, little or no fines.
			GM	Silly gravels, gravel-sand-silt mixtures, non-plastic fines.
			GC	Clayey gravels, gravel-sand-clay mixtures, plastic fines.
	SANDS More than 50% of coarse fraction is smaller than No. 4 sieve	Clean Sands (less than 5% fines)	SW	Well-graded sands, gravelly sands, little or no fines.
		Sands with fines	SP	Poorly-graded sands or gravelly sands, little or no fines.
			SM	Silly sands, sand-silt mixtures, non-plastic fines.
			SC	Clayey sands, sand-clay mixtures, plastic fines.
FINE GRAINED SOILS More than 50% material smaller than No. 200 sieve size	SILTS AND CLAYS Liquid limit is less than 50%	ML	Inorganic silts, rock flour, clayey silts with slight plasticity.	
		CL	Inorganic clays of low to medium plasticity, (lean clay).	
		OL	Organic silts and organic clays of low plasticity.	
	SILTS AND CLAYS Liquid limit is greater than 50%	MH	Inorganic silts, elastic.	
		CH	Inorganic clays of high plasticity, fat clays.	
		OH	Organic clays of high plasticity.	
HIGHLY ORGANIC SOILS			PT	Peat.

DEFINITION OF TERMS AND SYMBOLS

COHESIONLESS	Density	Standard Penetration Resistance in Blows/Foot	I 2" OUTSIDE DIAMETER SPLIT SPOON SAMPLER I 2.4" INSIDE DIAMETER RING SAMPLER OR SHELBY TUBE SAMPLER ∇ WATER LEVEL (DATE) Tr TORVANE READINGS, tsf Pp PENETROMETER READING, tsf DD DRY DENSITY, pounds per cubic foot LL LIQUID LIMIT, percent PI PLASTIC INDEX N STANDARD PENETRATION, blows per foot
	Very loose 0-4 Loose 4-10 Medium dense 10-30 Dense 30-50 Very dense >50		
COHESIVE	Consistency	Standard Penetration Resistance in Blows/Foot	
	Very soft 0-2 Soft 2-4 Medium stiff 4-8 Stiff 8-16 Very stiff 16-32 Hard >32		

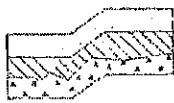

Terra Associates, Inc.

Consultants in Geotechnical Engineering
Geology and
Environmental Earth Sciences

UNIFIED SOIL CLASSIFICATION SYSTEM
MERCER ISLAND NORTH
MERCER ISLAND, WASHINGTON

Proj. No. T-6714

Date MAY 2012

Figure A-1

LOG OF BORING NO. B-1

Figure No. A-2

Project: Mercer Island North Project No: T-6714 Date Drilled: 4-25-12

Client: PMF Investments Driller: BORETEC Logged By: CSD

Location: Mercer Island, Washington Approx. Elev: N/A

Depth (ft)	Sample Interval	Soil Description	Consistency/ Relative Density	Moisture Content % Wp -----x----- Wl 10 20 30 40	Pocket Penetrometer				Observ. Well
					TSF				
					1	2	3	4	
1		(4 inches ASPHALT)							
2		FILL: brown sand with silt and gravel, fine to coarse grained, moist.	Medium Dense		18				
3									
4		FILL: brown and gray silty sand with gravel, fine to medium grained, moist.	Loose	18.3 x	3				
5									
6		Dark brown SILT with organics, fine grained, moist.	Loose						
7		Gray SILT, fine grained, moist, sand pockets, slight mottling.	Stiff	40.0 x	14				
8									
9		Brown SILT, fine grained, moist to wet, sand pockets.	Medium Stiff	28.2 x	4				
10									
11		Gray silty SAND, fine to medium grained, moist to wet. (SM)	Very Dense	22.5 x	42				
12									
13		*See Next Page		14.5 x					
14									
15									
16									
17									
18									
19									
20									

Note: This borehole log has been prepared for geotechnical purposes. This information pertains only to this boring location and should not be interpreted as being indicative of other areas of the site.



Terra Associates, Inc.
 Consultants in Geotechnical Engineering, Geology and Environmental Earth Sciences

LOG OF BORING NO. B-1

Figure No. A-2

Project: Mercer Island North Project No: T-6714 Date Drilled: 4-25-12
 Client: PMF Investments Driller: BORETEC Logged By: CSD
 Location: Mercer Island, Washington Approx. Elev: N/A

Depth (ft)	Sample Interval	Soil Description	Consistency/ Relative Density	Moisture Content % Wp -----x----- Wl 10 20 30 40	Pocket Penetrometer				Observ. Well	
					1	2	3	4		
					SPT (N)					
					Blows/ft					
21		Gray silty SAND, fine to medium grained, moist to wet. (SM)	Very Dense	12.5 x					50/4	
22										
23										
24										
25						15.2 x				50/6
26										
27		Gray SILT, fine grained, moist. (ML)	Hard							
28										
29										
30				12.4 x				50/4		
31		Test boring terminated at 31 feet. Perched groundwater observed at 13 feet during drilling. Boring converted to 2-inch monitoring well.								
32										
33										
34										
35										
36										
37										
38										
39										
40										

Note: This borehole log has been prepared for geotechnical purposes. This information pertains only to this boring location and should not be interpreted as being indicative of other areas of the site.



Terra Associates, Inc.
 Consultants in Geotechnical Engineering, Geology and Environmental Earth Sciences

LOG OF BORING NO. B-2

Figure No. A-3

Project: Mercer Island North Project No: T-6714 Date Drilled: 4-25-12

Client: PMF Investments Driller: BORETEC Logged By: CSD

Location: Mercer Island, Washington Approx. Elev: N/A

Depth (ft)	Sample Interval	Soil Description	Consistency/ Relative Density	Moisture Content % Wp ---x--- Wl 10 30 50 70 90	Pocket Penetrometer					
					TSP			SPT (N)		
					1	2	3	4	Blows/ft	
1		(4 inches ASPHALT)								
2		FILL: brown gravel, fine to coarse grained, saturated.		43.0 x					13	
3										
4		Gray sandy SILT, fine grained, moist to wet, mottled. (ML) LL=33 PL=26 PI=7	Soft	40.0 x					6	
5										
6										
7						43.7 x				4
8										
9										
10				50.3 x					2	
11										
12										
13		Gray SILT, fine grained, moist to wet. (ML)	Hard							
14										
15						17.5 x				41
16										
17										
18										
19										
20			Loose	25.1 x					6	
21										
22										
23		Gray SAND, fine to medium grained, saturated. (SP)	Medium Dense							
24										
25						23.2 x				29
26										
27										
28										
29			Dense							
30				20.6 x						
31										
32										
33		Test boring terminated at 31.5 feet.								
34		Groundwater observed at 19.5 feet during drilling.								
35										

80/5"

Note: This borehole log has been prepared for geotechnical purposes. This information pertains only to this boring location and should not be interpreted as being indicative of other areas of the site.



Terra Associates, Inc.
 Consultants in Geotechnical Engineering, Geology and Environmental Earth Sciences

LOG OF BORING NO. B-3

Figure No. A-4

Project: Mercer Island North Project No: T-6714 Date Drilled: 4-25-12
 Client: PMF Investments Driller: BORETEC Logged By: CSD
 Location: Mercer Island, Washington Approx. Elev: N/A

Depth (ft)	Sample Interval	Soil Description	Consistency/ Relative Density	Moisture Content % Wp -----x----- Wl 10 30 50 70 90	Pocket Penetrometer			
					Δ	TSF		
					1	2	3	4
					SPT (N) Blows/ft			
					10	20	30	40
1		(4 inches ASPHALT)						
2		FILL: gray silty sand with gravel, fine to medium grained, moist.	Medium Dense					
3								
4								
5				46.4				8
6				x				8
7								
8		Gray SILT, fine grained, moist, occasional brown sand pocket, mollified. (ML)						
9								
10				46.2				4
11		LL=34		x				4
12		PL=27						
13		PI=7	Medium Stiff					
14								
15		*At 15 feet soil becomes wet, no sand pockets		43.4				4
16				x				4
17								
18								
19								
20				20.8				39
21				x				39
22				17.2				
23				x				
24								
25				21.0				33
26		Gray SAND, fine to medium grained, saturated, (SP)	Dense	x				33
27								
28								
29								
30				26.7				80/5"
31				x				80/5"
32								
33		Test boring terminated at 31.5 feet.						
34		Groundwater observed at 21 feet during drilling.						
35		Groundwater observed at 15.5 feet after drilling.						
36								
37								
38								
39								
40								

Note: This borehole log has been prepared for geotechnical purposes. This information pertains only to this boring location and should not be interpreted as being indicative of other areas of the site.

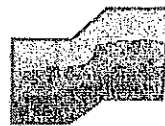

Terra Associates, Inc.
 Consultants in Geotechnical Engineering, Geology and Environmental Earth Sciences

LOG OF BORING NO. B-4

Figure No. A-5

Project: Mercer Island North Project No: T-6714 Date Drilled: 4-25-12
 Client: PMF Investments Driller: BORETEC Logged By: CSD
 Location: Mercer Island, Washington Approx. Elev: N/A

Depth (ft)	Sample Interval	Soil Description	Consistency/ Relative Density	Moisture Content % Wp -----x----- Wl 10 30 50 70 90	Pocket Penetrometer			
					Δ	TSF	Δ	SPT (N) Blows/ft
1		(3.5 inches ASPHALT)						
2								
3								
4								
5		FILL; mix of brown sand with silt and gravel and gray silty sand with gravel, fine to coarse grained, moist.	Medium Dense	16.9 x			24	
6								
7								
8								
9								
10								56
11		Brown silty SAND, fine to medium grained, moist. (SM)	Very Dense	15.2 x				
12								
13								
14								
15								90/4"
16								
17								
18								
19								
20		Gray SILT, fine grained, moist. (ML)	Hard	11.2 x				50/5"
21								
22								
23								
24								
25								
26								57
27								
28								
29		Gray SAND, fine to medium grained, saturated. (SP)	Medium Dense	21.9 x			19	
30								
31								
32								
33		Test boring terminated at 31.5 feet.						
34		Groundwater observed at 29 feet during drilling.						
36		Groundwater observed at 22 feet after drilling.						
37								
38								
39								
40								

Note: This borehole log has been prepared for geotechnical purposes. This information pertains only to this boring location and should not be interpreted as being indicative of other areas of the site.

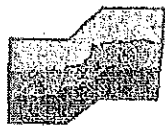

Terra Associates, Inc.
 Consultants in Geotechnical Engineering, Geology and Environmental Earth Sciences

Particle Size Distribution Report

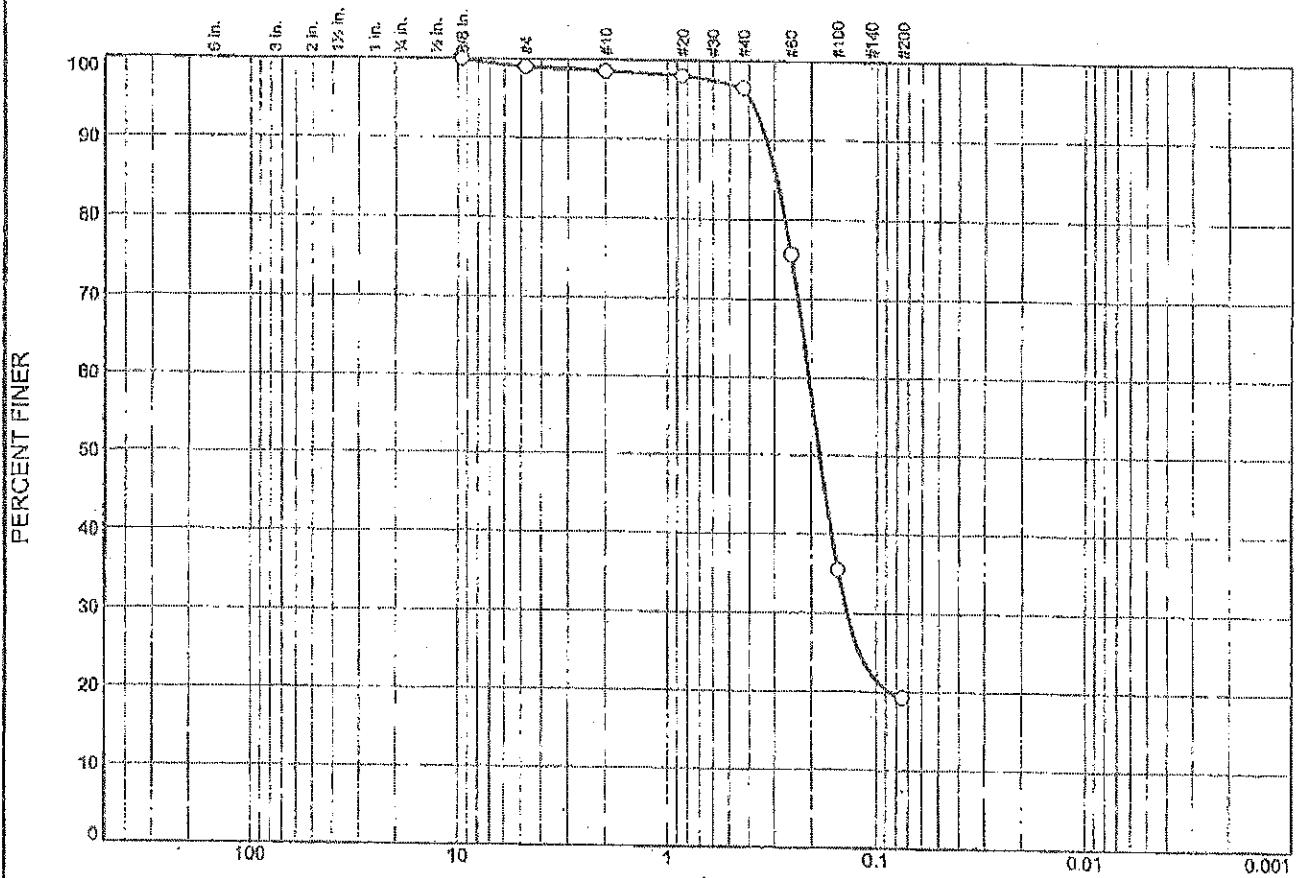

GRAIN SIZE - mm.

%	+3"	% Gravel		% Sand			% Fines			
		Coarse	Fine	Coarse	Medium	Fine	Silt	Clay		
○	0.0	0.0	1.0	0.5	1.9	77.3	19.3			
×	LL	PL	D ₈₅	D ₆₀	D ₅₀	D ₃₀	D ₁₅	D ₁₀	C _c	C _u
○			0.2925	0.2051	0.1822	0.1354				

Material Description						USCS	AASHTO
○ Silty SAND						SM	

Project No. T-6714 Client: PMF Investments
 Project: Mercer Island North
 Mercer Island, Washington
 ○ Location: Test Boring B-1 Depth: -25' Sample Number: 7

 Terra Associates, Inc.
 Kirkland, WA

Remarks:
 ○ Tested on 4/27/2012

Figure A-6

Tested By: BS

Project : Mercer Island Multi-Family		Boring No. B-1	
Project No. 1350	Date : 10-2-12		
Client : Continental Pacific	Elevation 92 Feet		
Location: East Side	Logged By: Paul Bonifaci		

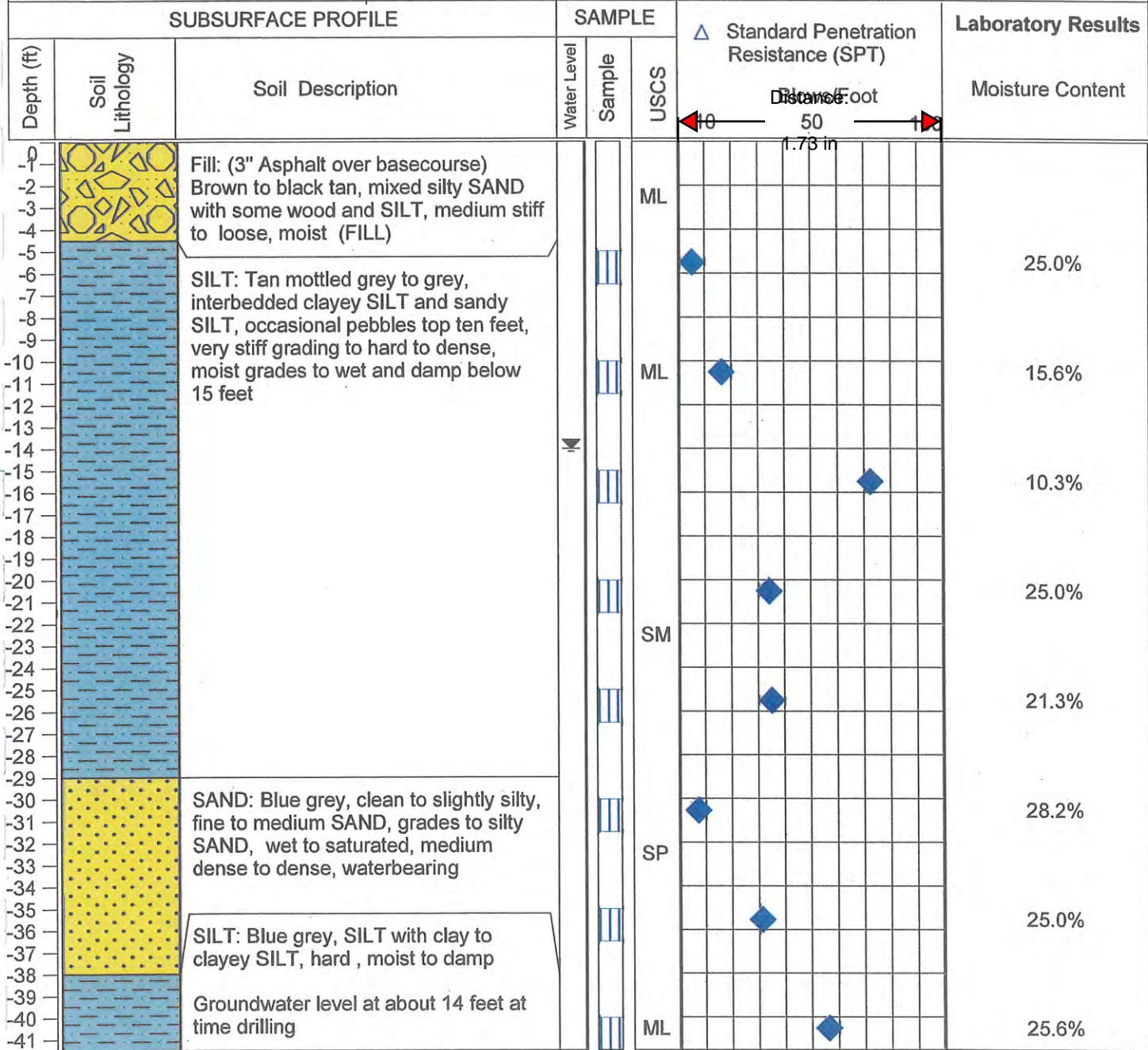

**ABPB Consulting
Geotechnical Consultants**

12525 Willows Road, Suite 80, Kirkland, Washington (425) 820-2544

Project : Mercer Island Multi-Family
Project No. 1350 **Date :** 10-2-12
Client : Continental Pacific **Elevation** 82 Feet
Location: East Side **Logged By:** Paul Bonifaci

Boring No. B-2

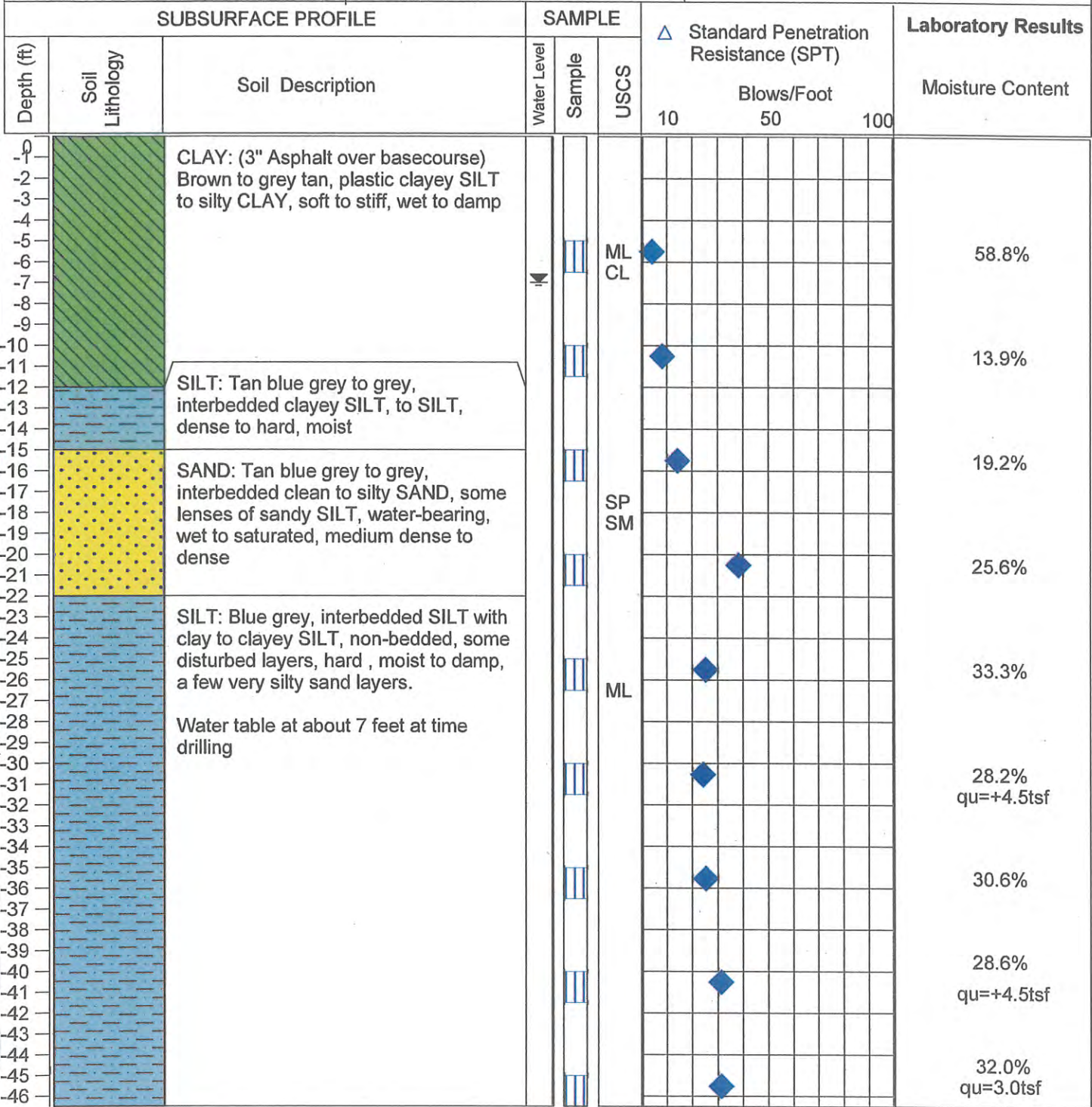

ABPB Consulting
Geotechnical Consultants

12525 Willows Road, Suite 80, Kirkland, Washington (425) 820-2544

Project : Mercer Island Multi-Family			Boring No. B-3
Project No. 1350	Date :	10-2-12	
Client : Continental Pacific	Elevation	85 Feet	
Location: NW corner	Logged By:	Paul Bonifaci	

SUBSURFACE PROFILE			SAMPLE			Standard Penetration Resistance (SPT)			Laboratory Results
Depth (ft)	Soil Lithology	Soil Description	Water Level	Sample	USCS	Blows/Foot			Moisture Content
						10	50	100	
-0		FILL: (3" Asphalt over basecourse)							
-1		Brown to grey tan, silty gravelly SAND (FILL), loose, moist			SM				
-2		PEAT: Interbedded brown, organic PEAT, mixed with silty organic CLAY, very soft, wet			Pt				65.2%
-3									
-4									
-5									
-6									
-7									
-8									
-9		CLAY: Tan blue grey, interbedded silty CLAY and clayey SILT, scattered organic fragments, very soft to soft, damp to wet							
-10									
-11									45.0% qu=0.75tsf
-12									
-13									
-14									
-15									
-16									44.7% qu=0.25tsf
-17									
-18									
-19									
-20		SILT: Blue grey, interbedded SILT with clay to clayey SILT, non-bedded, occasional sandy SILT layers, hard, moist to damp, a few very silty sand layers.							
-21									26.5%
-22									
-23									
-24									
-25									
-26									21.9% qu=2.5tsf
-27		Water table at about 7 feet at time drilling							
-28									
-29									
-30									
-31									37.9%
-32									
-33									
-34									
-35									
-36									20.0% qu=+4.5tsf
-37									
-38									
-39									
-40									
-41									29.0

**ABPB Consulting
Geotechnical Consultants**

12525 Willows Road, Suite 80, Kirkland, Washington (425) 820-2544

Date : Oct. 2012	Project Name: Mercer Island Multi-Family	Figure 5
------------------	--	----------

Project : Mercer Island Multi-Family

Project No. 1350

Date : 10-2-12

Client : Continental Pacific

Elevation 81 Feet

Location: SW side

Logged By: Paul Bonifaci

Boring No. B -4

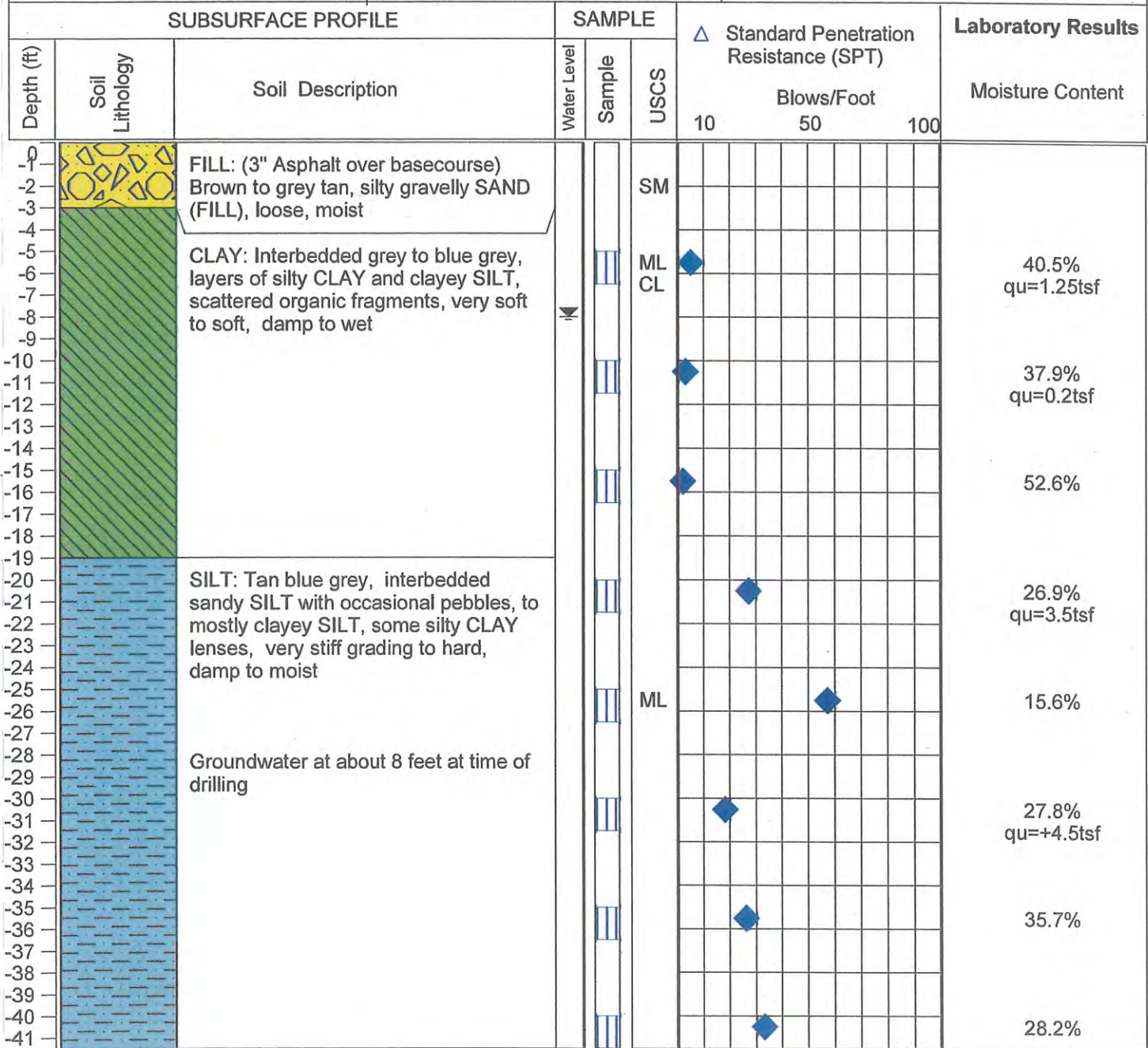

**ABPB Consulting
Geotechnical Consultants**

12525 Willows Road, Suite 80, Kirkland, Washington (425) 820-2544

Date : Oct. 2012

Project Name: Mercer Island Multi-Family

Figure 6

Project : Mercer Island Multi-Family		Boring No. M-1	
Project No. 1350	Date : 10-19-12		
Client : Continental Pacific	Elevation 87 feet		
Location: South Side	Logged By: Terry Bukowsky		

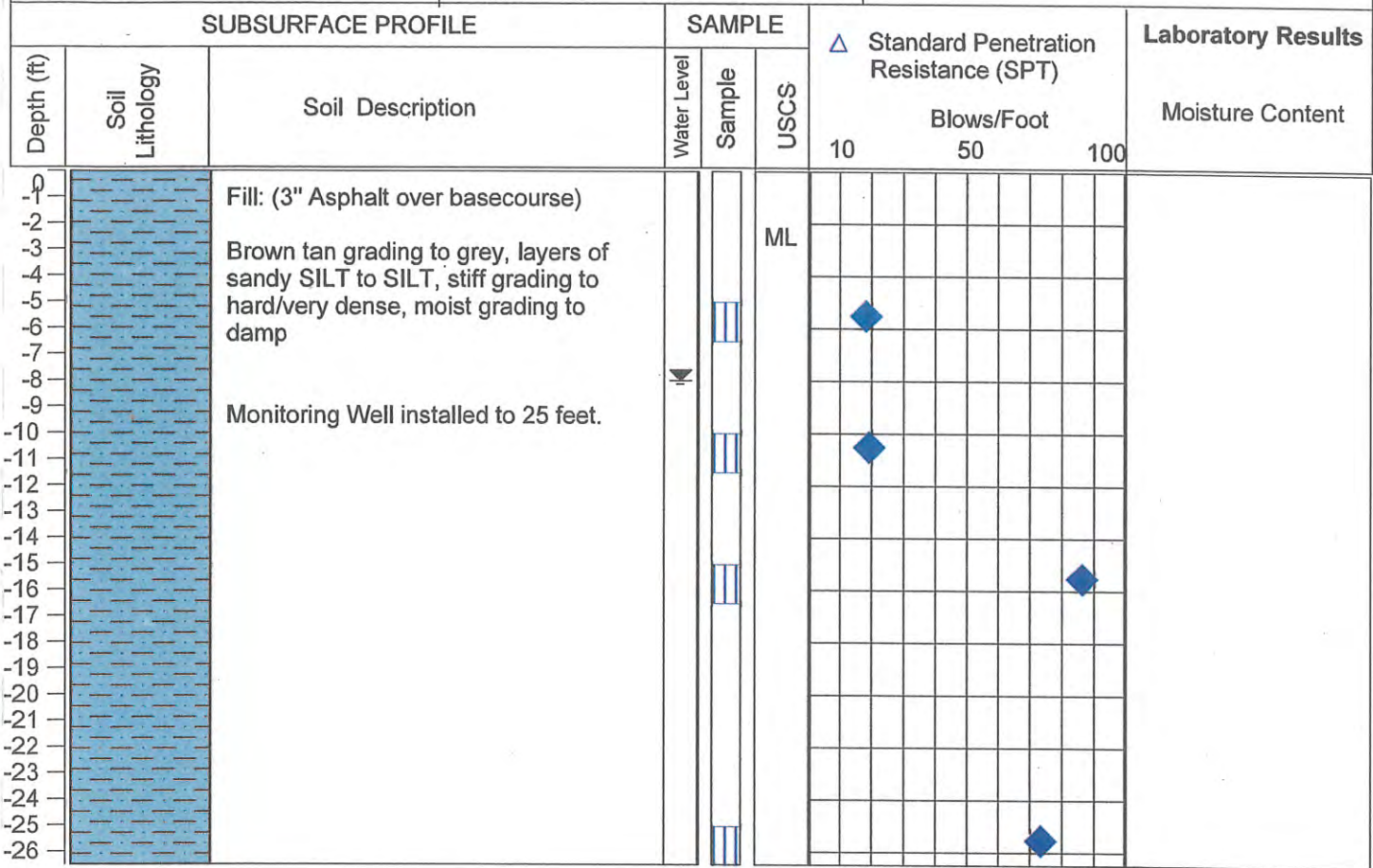

**ABPB Consulting
Geotechnical Consultants**

12525 Willows Road, Suite 80, Kirkland, Washington (425) 820-2544

Date : Oct. 2012

Project Name: Mercer Island Multi-Family

Figure 7

Project : Mercer Island Multi-Family
Project No. 1350 **Date :** 10-20-12
Client : Continental Pacific **Elevation** 83 feet
Location: South Side **Logged By:** Terry Bukowsky

Boring No. M-2

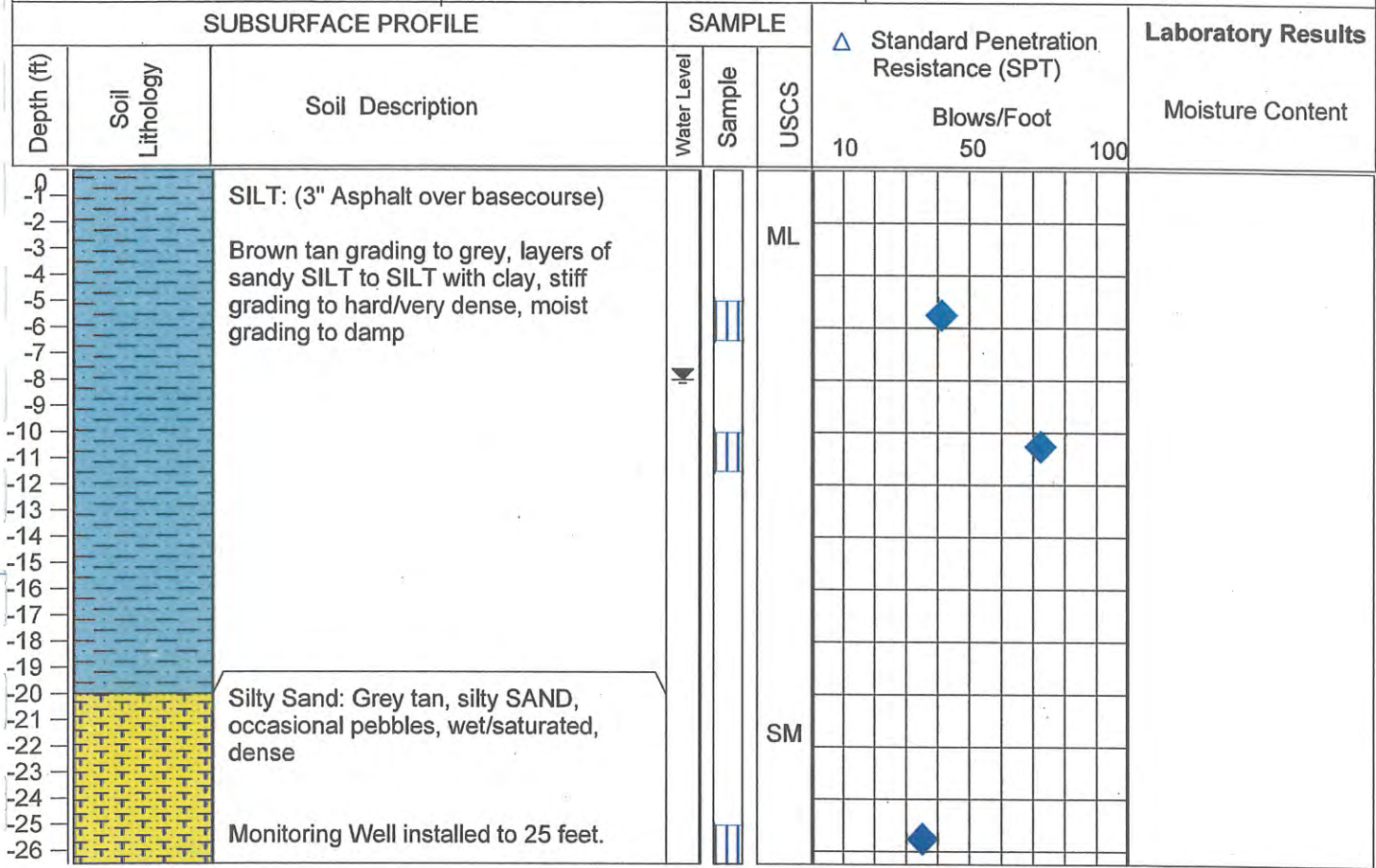

ABPB Consulting
Geotechnical Consultants

12525 Willows Road, Suite 80, Kirkland, Washington (425) 820-2544

Project : Mercer Island Multi-Family		Boring No. M-3	
Project No. 1350	Date : 10-20-12		
Client : Continental Pacific	Elevation 82 feet		
Location: South Side	Logged By: Terry Bukowsky		

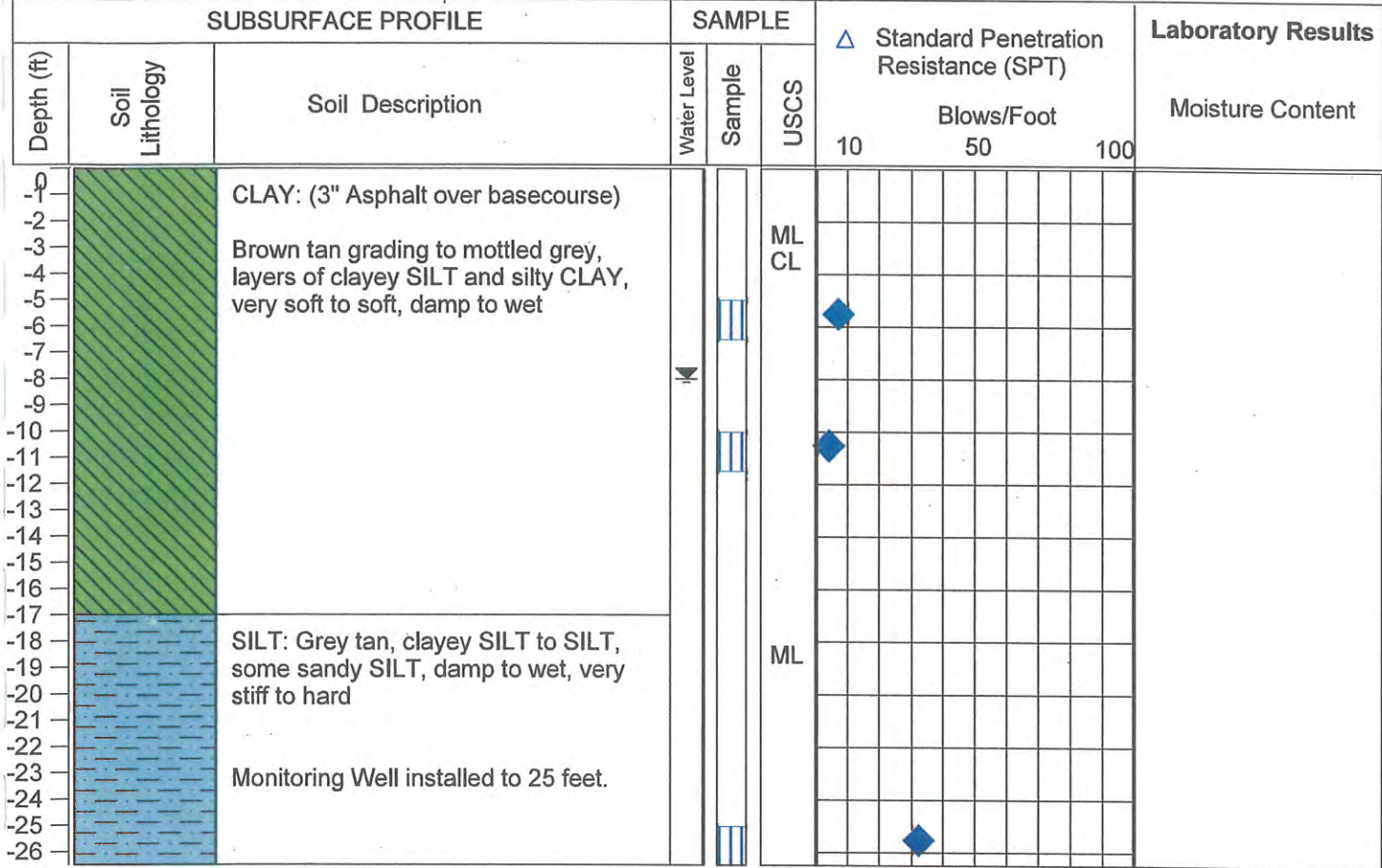

**ABPB Consulting
Geotechnical Consultants**

12525 Willows Road, Suite 80, Kirkland, Washington (425) 820-2544

Appendix B

Infiltration Feasibility Map

This page intentionally left blank.

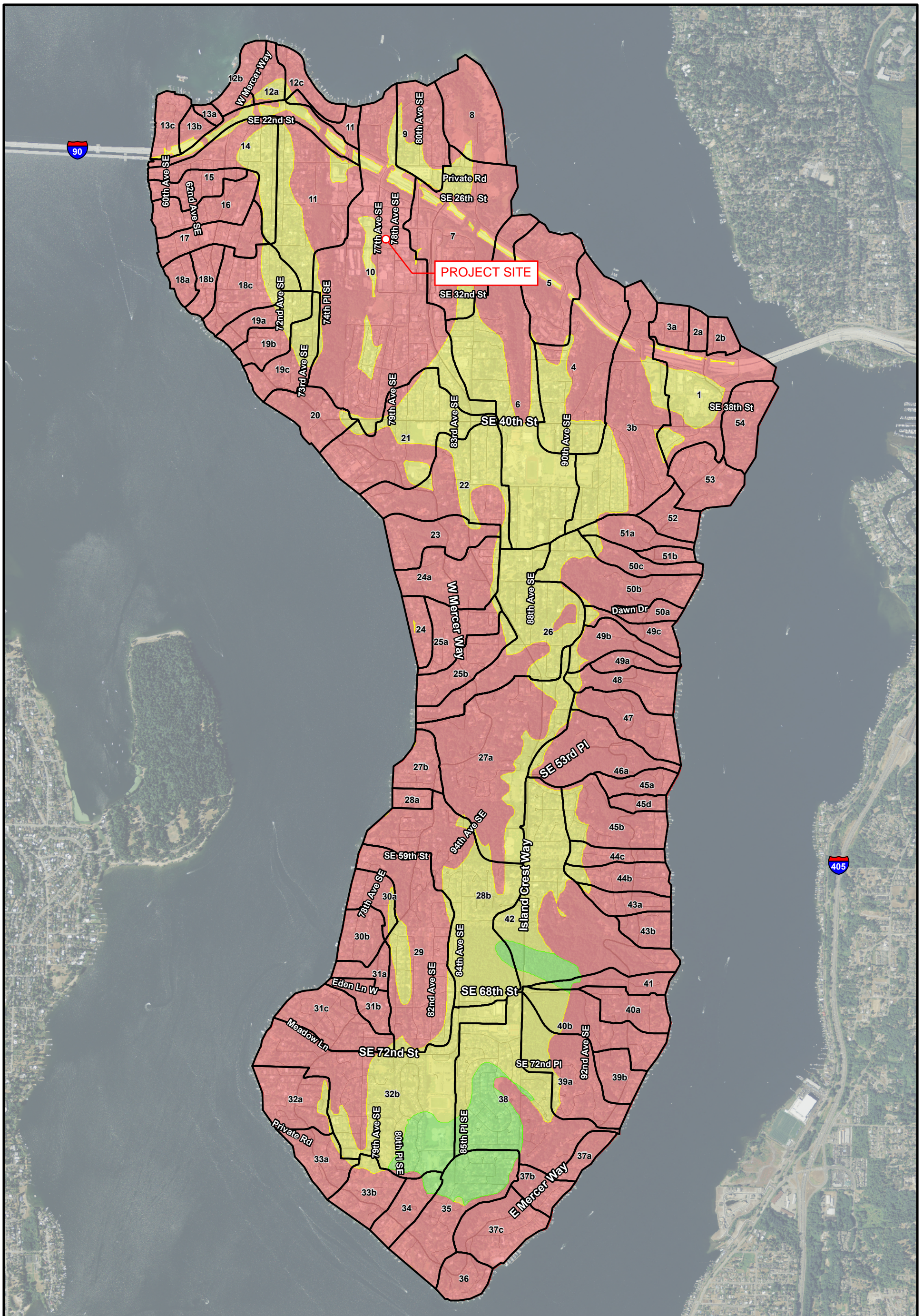

Legend

- Infiltrating LID facilities may be feasible, and soil has high infiltration potential
- Infiltrating LID facilities may be feasible, and soil has moderate infiltration potential
- Infiltrating LID facilities are not permitted
- Storm drainage basin

* Map is intended to be used for planning purposes only. Site-specific analysis is required prior to design and construction of LID facilities.

Figure 3. Low impact development infiltration feasibility on Mercer Island.

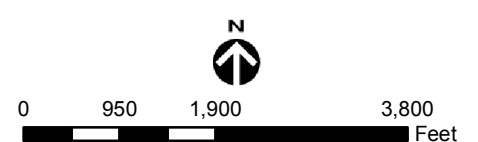

Aerial photography: USDA (2009)
 K:\Projects\10-04816-000\Project\lid_feasibility-report-11x17.mxd

Appendix C

Offsite Drainage Basin Maps

This page intentionally left blank.



SEE NEXT PAGE FOR CONTINUATION

60" WSDOT TRUNK MAIN

KC TRUNK MAIN, VARIES 48" TO 60"

EX 42" CMI STORM MAIN IN 77TH AVE SE

PROJECT SITE

EX 8" CMI STORM MAIN IN 78TH AVE SE

EX 24" CMI STORM MAIN IN SE 29TH ST

- ### Legend
- 10ft Lidar Contours (2)
 - 2ft Lidar Contours (2C)
 - Unpiped Watercourse
 - Type "F" = Fish
 - Type "Np" = Non-Fish
 - Type "Ns" = Non-Fish (Unverified)
 - Type "Np" = Non-Fish (Unverified)
 - Type "Ns" = Non-Fish (Unverified)
 - Piped Watercourse
 - Address
 - Building
 - Property Line
 - Docks
 - Freeway
 - Major Street
 - Street
 - Paved Driveway
 - Paved Road
 - Paved Parking Area
 - Parks
 - Lake Washington

1:2,500

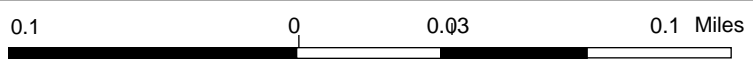

Disclaimer: These maps were developed by the City of Mercer Island and are intended to be a general purpose digital reference tool. These maps are not an accepted legal instrument for describing, establishing, recording or maintaining descriptions for property concerns or boundaries. The City makes no representation or warranty with respect to the accuracy or currency of these data sets, especially in regard to labeling of surveyed dimensions, or agreement with official sources such as records of survey, or mapped locations of features.

Notes
 CMI = City of Mercer Island
 KC = King County
 WSDOT = Washington Dept of Transportation

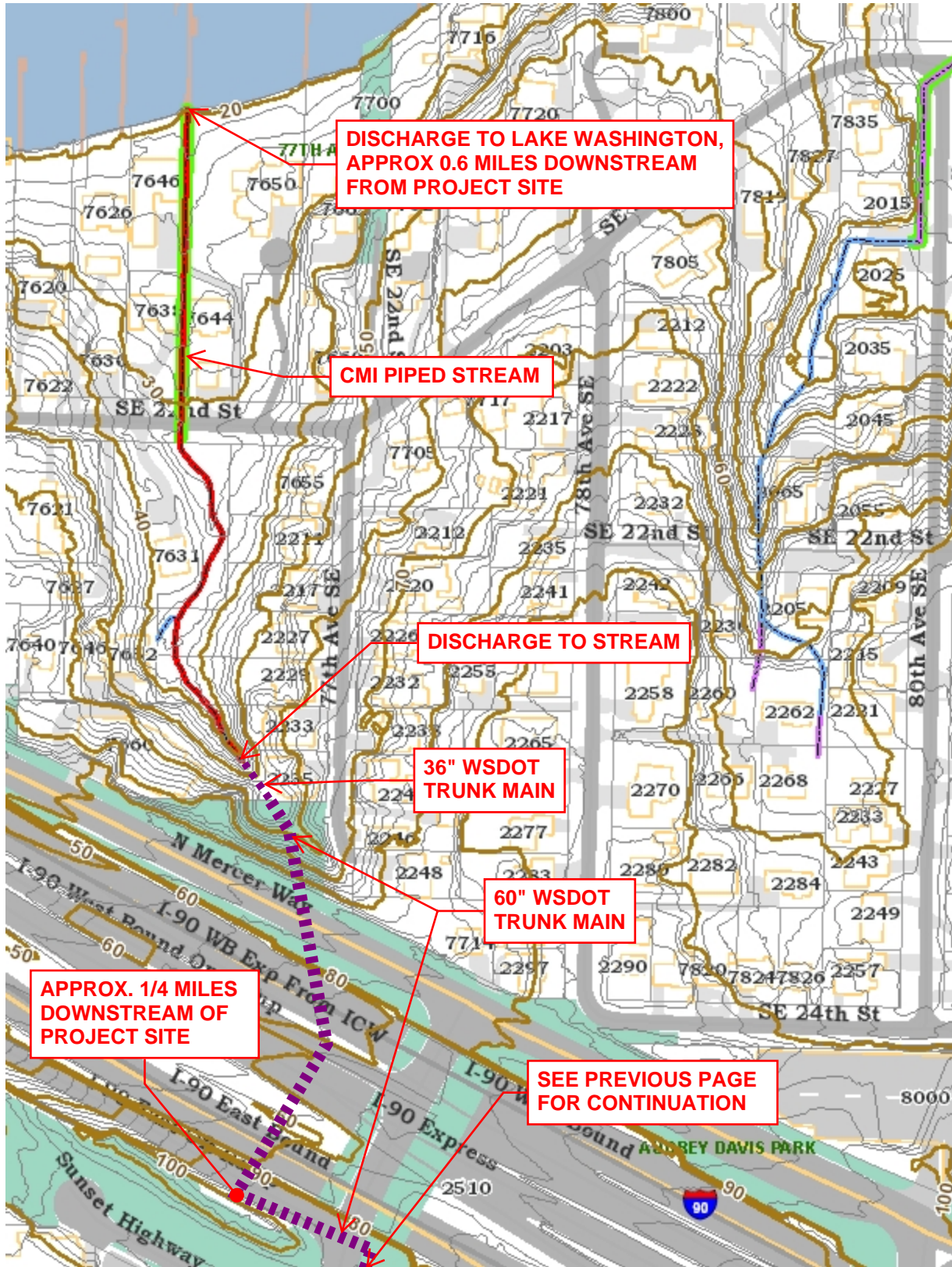

Legend

- 10ft Lidar Contours (2)
- 2ft Lidar Contours (20)
- Unpipd Watercourse
 - Type "F" = Fish
 - Type "Np" = Non-Fish
 - Type "Ns" = Non-Fish (Unverified)
 - Type "Np" (Unverified)
 - Type "Ns" (Unverified)
- Piped Watercourse
- Address
- Building
- Property Line
- Docks
- Freeway
- Major Street
- Street
- Paved Driveway
- Paved Road
- Paved Parking Area
- Parks
- Lake Washington

1:2,500



0.1 0 0.03 0.1 Miles

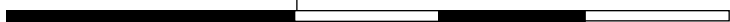

Disclaimer: These maps were developed by the City of Mercer Island and are intended to be a general purpose digital reference tool. These maps are not an accepted legal instrument for describing, establishing, recording or maintaining descriptions for property concerns or boundaries. The City makes no representation or warranty with respect to the accuracy or currency of these data sets, especially in regard to labeling of surveyed dimensions, or agreement with official sources such as records of survey, or mapped locations of features.

Notes

CMI = City of Mercer Island
 KC = King County
 WSDOT = Washington Dept of Transportation

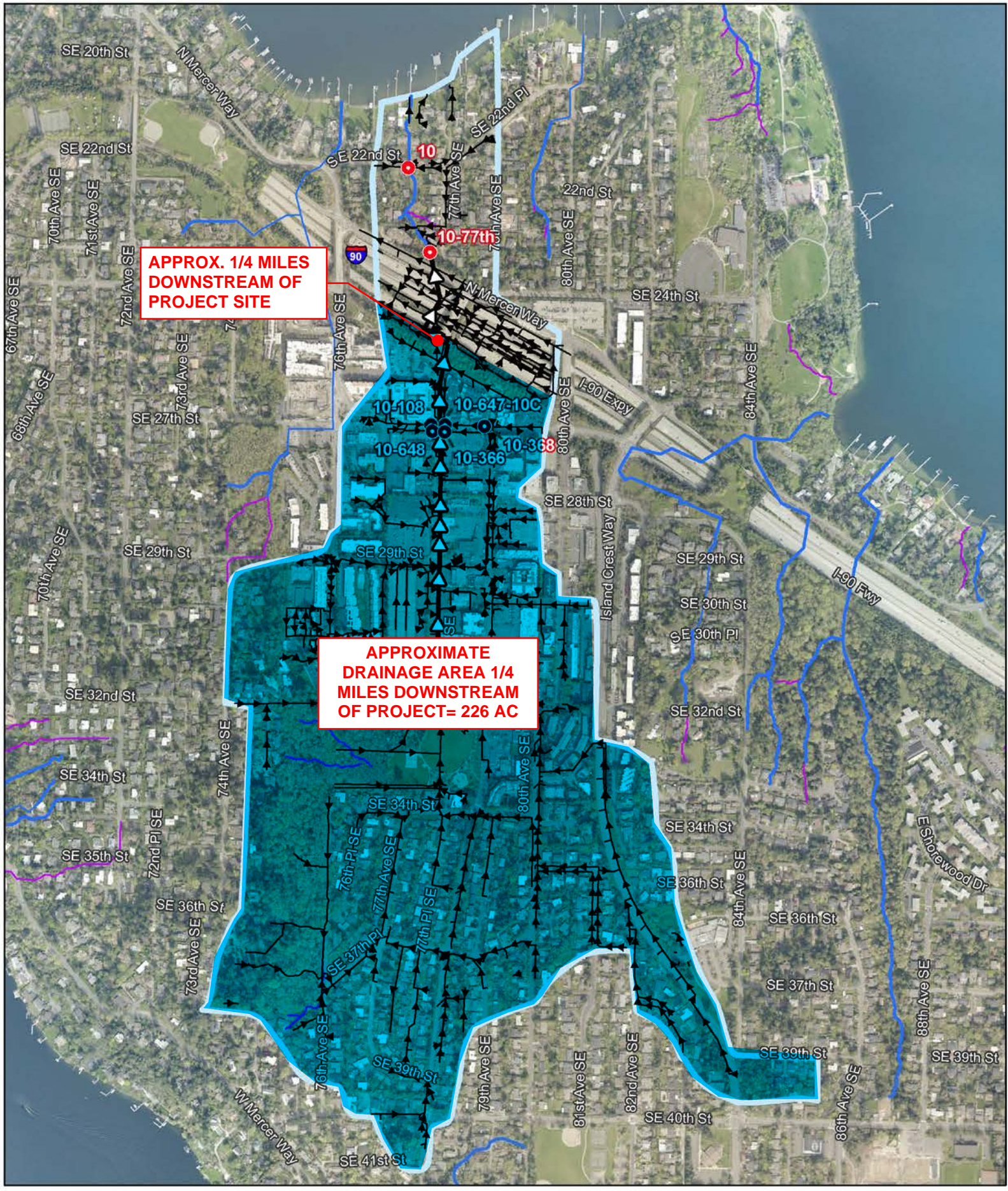

**APPROX. 1/4 MILES
DOWNSTREAM OF
PROJECT SITE**

**APPROXIMATE
DRAINAGE AREA 1/4
MILES DOWNSTREAM
OF PROJECT = 226 AC**

Map courtesy of 2015-2016 Water Quality Monitoring in Basin 10 Report by King County

Mercer Island Basin 10

Appendix D

Project Site Drainage Basin Map

This page intentionally left blank.

Z:\1600001-1600999\1600596 Mercer Island - 2885 78th Ave SE\Project Documents\Storm Drainage\Drainage Report\Working Files\Appendix D Existing Drainage Basin Exhibit.dwg
 whl:nl
 Sep 22, 2021 9:58am

LEGEND:

- PROPERTY LINE
- SUB-BASIN BOUNDARY = 72,306 SF

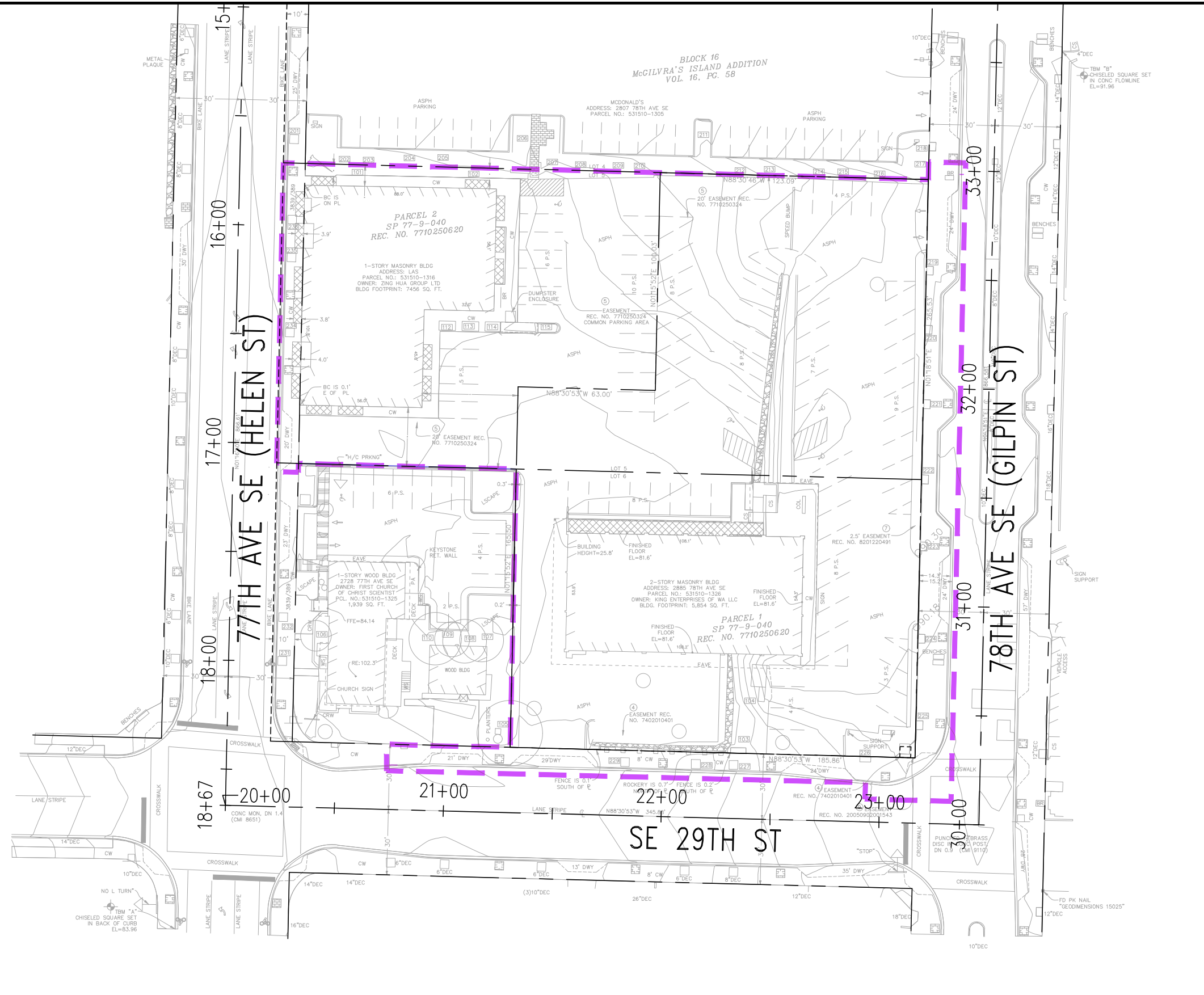





Project Title MERCER ISLAND MIXED-USE		Drawing Title EXISTING SITE DRAINAGE BASIN MAP		ASI/RFI/CSK Number	
Client		1601 5th Avenue, Suite 1600 Seattle, WA 98101 206.622.5822 www.kpff.com		Drawing Reference	Scale 1" = 50'
				Date 9/30/2021	Drawn/Ck'd By WHL

Z:\1600001-1600999\Mercer Island - 2885 78th Ave SE\Project Documents\Storm Drainage\Drainage Report\Working Files\Appendix D Proposed Drainage Basin Exhibit.dwg
 whr:nl
 Sep 22, 2021 9:59pm

LEGEND:

-  PROPERTY LINE
-  SUB-BASIN BOUNDARY

SURFACE AREA BREAKDOWN TO DETENTION		
SYMBOL	SURFACE DESCRIPTION	AREA (SF)
	ROOF	43,366
	HARD SURFACE	15,851
	POLLUTION GENERATING HARD SURFACE	3,490
	LANDSCAPING ABOVE STRUCTURE (GREEN ROOF)	6,169
	LANDSCAPING ON-GRADE	3,430
	TOTAL AREA TO DETENTION	72,306

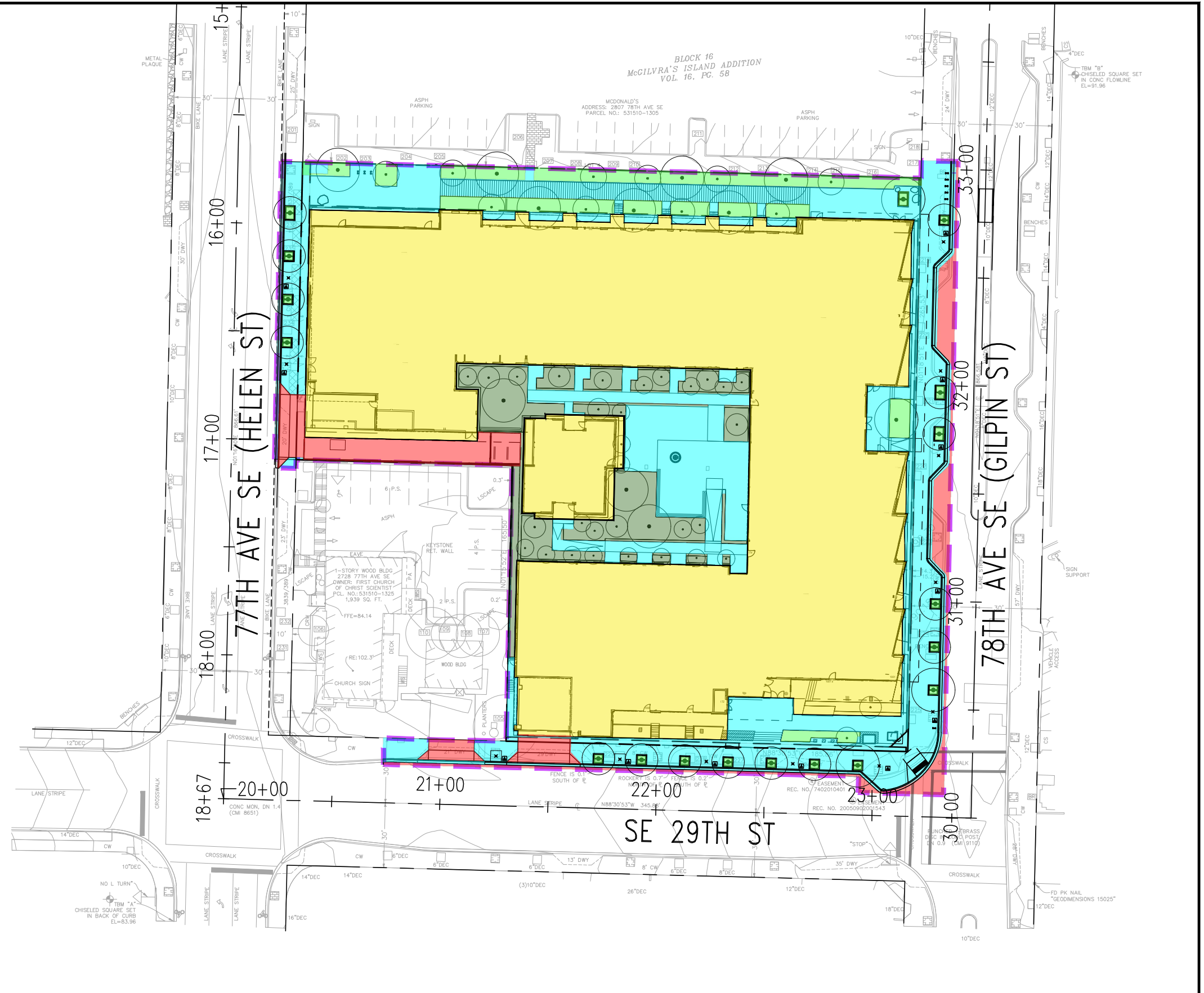
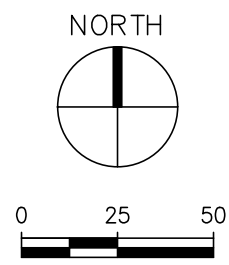

Project Title MERCER ISLAND MIXED-USE		Drawing Title PROPOSED SITE DRAINAGE BASIN MAP		ASI/RFI/CSK Number	
Client		 1601 5th Avenue, Suite 1600 Seattle, WA 98101 206.622.5822 www.kpff.com		Drawing Reference	Scale 1" = 50'
				Date 9/30/2021	Drawn/Ck'd By WHL

Appendix E

Minimum Requirements Flow Charts

This page intentionally left blank.

Figure I-2.4.1 Flow Chart for Determining Requirements for New Development

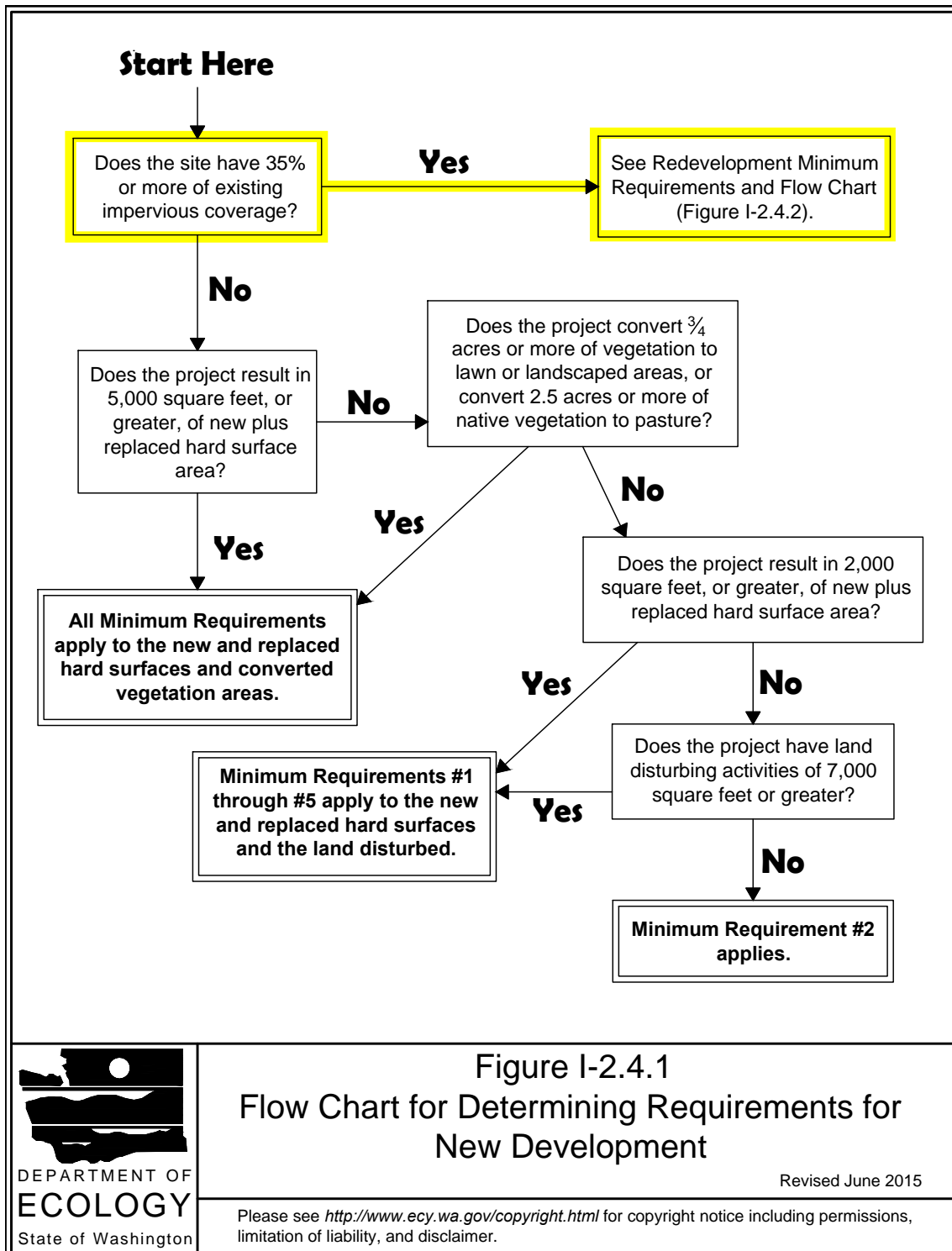
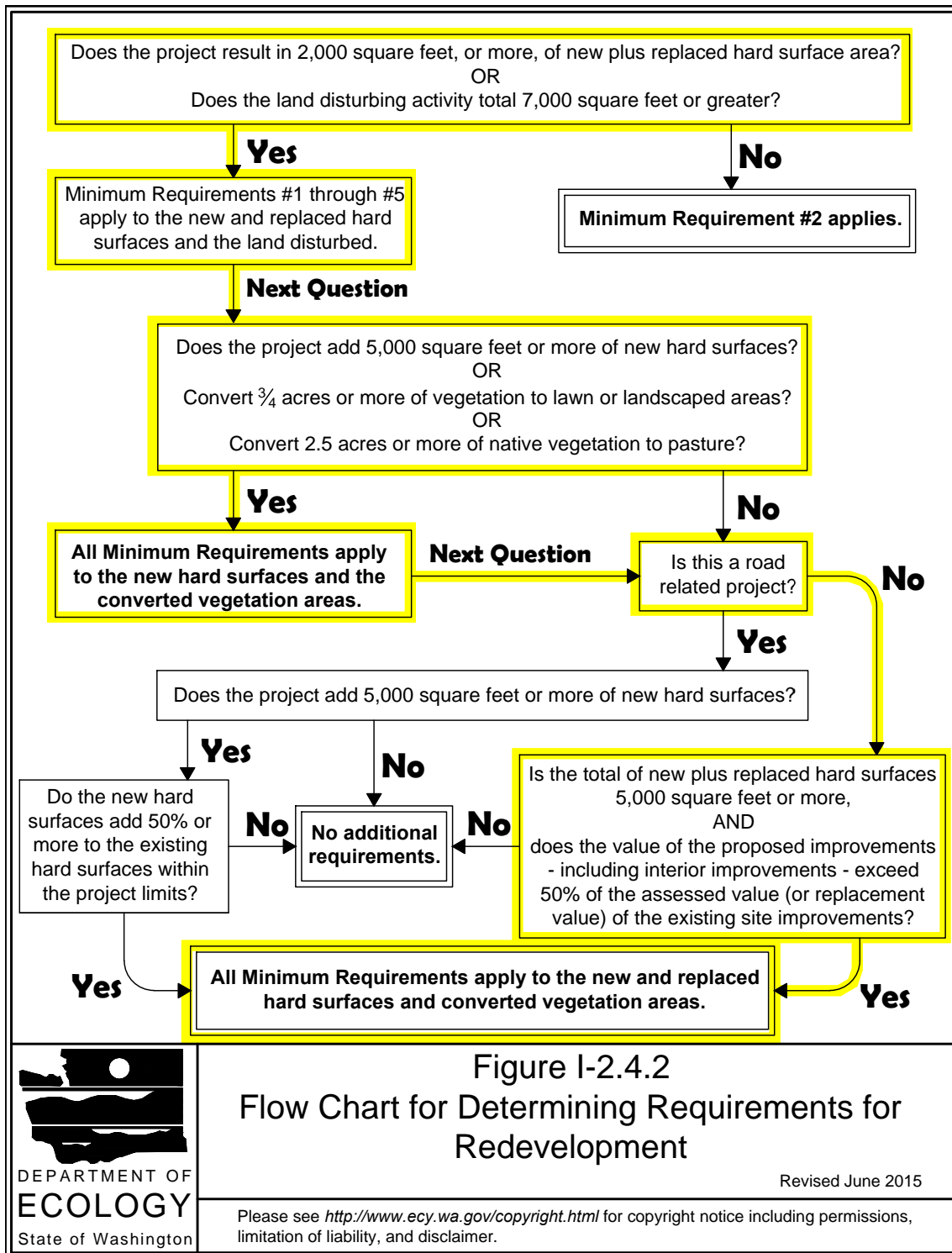

Figure I-2.4.1
Flow Chart for Determining Requirements for New Development

Revised June 2015

Please see <http://www.ecy.wa.gov/copyright.html> for copyright notice including permissions, limitation of liability, and disclaimer.

Figure I-2.4.2 Flow Chart for Determining Requirements for Redevelopment



**Figure I-2.4.2
Flow Chart for Determining Requirements for
Redevelopment**

Revised June 2015

Please see <http://www.ecy.wa.gov/copyright.html> for copyright notice including permissions, limitation of liability, and disclaimer.

Appendix F

MGSFlood Report

This page intentionally left blank.

MGS FLOOD PROJECT REPORT

Program Version: MGSFlood 4.52
Program License Number: 200410007
Project Simulation Performed on: 09/22/2021 10:24 PM
Report Generation Date: 09/22/2021 10:24 PM

Input File Name: MIMU Detention Vault.fld
Project Name: Mercer Island
Analysis Title:
Comments: Detention Vault

PRECIPITATION INPUT

Computational Time Step (Minutes): 15

Extended Precipitation Time Series Selected
Climatic Region Number: 15

Full Period of Record Available used for Routing
Precipitation Station : 96004005 Puget East 40 in_5min 10/01/1939-10/01/2097
Evaporation Station : 961040 Puget East 40 in MAP
Evaporation Scale Factor : 0.750

HSPF Parameter Region Number: 1
HSPF Parameter Region Name : USGS Default

***** Default HSPF Parameters Used (Not Modified by User) *****

***** WATERSHED DEFINITION *****

Predevelopment/Post Development Tributary Area Summary

	Predeveloped	Post Developed
Total Subbasin Area (acres)	1.660	1.660
Area of Links that Include Precip/Evap (acres)	0.000	0.000
Total (acres)	1.660	1.660

-----SCENARIO: PREDEVELOPED

Number of Subbasins: 1

----- Subbasin : Predeveloped Area -----
-----Area (Acres) -----
Till Forest 1.660

Subbasin Total 1.660

-----SCENARIO: POSTDEVELOPED

Number of Subbasins: 1

----- Subbasin : Area to Detention Vault -----

	-----Area (Acres) -----
Till Grass	0.079
Green Roof	0.142
Impervious	1.439

Subbasin Total	1.660

***** LINK DATA *****

-----SCENARIO: PREDEVELOPED

Number of Links: 1

Link Name: New Copy Lnk1

Link Type: Copy
Downstream Link: None

***** LINK DATA *****

-----SCENARIO: POSTDEVELOPED

Number of Links: 1

Link Name: Detention Vault

Link Type: Structure
Downstream Link: None

Prismatic Pond Option Used

Pond Floor Elevation (ft)	:	67.00	
Riser Crest Elevation (ft)	:	74.50	
Max Pond Elevation (ft)	:	75.50	
Storage Depth (ft)	:	7.50	
Pond Bottom Length (ft)	:	112.5	
Pond Bottom Width (ft)	:	45.1	
Pond Side Slopes (ft/ft)	:	L1= 0.00 L2= 0.00 W1= 0.00 W2= 0.00	
Bottom Area (sq-ft)	:	5073.	
Area at Riser Crest El (sq-ft)	:	5,073.	
	(acres)	:	0.116
Volume at Riser Crest (cu-ft)	:	38,048.	
	(ac-ft)	:	0.873
Area at Max Elevation (sq-ft)	:	5073.	
	(acres)	:	0.116
Vol at Max Elevation (cu-ft)	:	43,121.	
	(ac-ft)	:	0.990

STORAGE
VOLUME

Hydraulic Conductivity (in/hr) : 0.00

Massmann Regression Used to Estimate Hydraulic Gradient

Depth to Water Table (ft) : 100.00

Bio-Fouling Potential : Low

Maintenance : Average or Better

Riser Geometry

Riser Structure Type : Circular

Riser Diameter (in) : 12.00

Common Length (ft) : 0.000

Riser Crest Elevation : 74.50 ft

Hydraulic Structure Geometry

Number of Devices: 3

---Device Number 1---

Device Type : Circular Orifice

Control Elevation (ft) : 67.00

Diameter (in) : 0.55

Orientation : Horizontal

Elbow : No

---Device Number 2---

Device Type : Circular Orifice

Control Elevation (ft) : 72.20

Diameter (in) : 1.00

Orientation : Horizontal

Elbow : Yes

--- Device Number 3 ---

Device Type : Rectangular Weir that Intersects the Riser Top

Invert Elevation (ft) : 73.70

Length (ft) : 0.020

FLOW CONTROL
STANDPIPE

*****FLOOD FREQUENCY AND DURATION STATISTICS*****

-----SCENARIO: PREDEVELOPED

Number of Subbasins: 1

Number of Links: 1

-----SCENARIO: POSTDEVELOPED

Number of Subbasins: 1

Number of Links: 1

***** Link: Detention Vault

***** Link WSEL

Stats

WSEL Frequency Data(ft)

(Recurrence Interval Computed Using Gringorten Plotting Position)

Tr (yrs) WSEL Peak (ft)

=====

1.05-Year 69.486

1.11-Year 69.763

1.25-Year 70.229

2.00-Year	71.160
3.33-Year	71.999
5-Year	72.599
10-Year	73.404
25-Year	73.925
50-Year	74.205
100-Year	74.326

*******Groundwater Recharge Summary*******

Recharge is computed as input to PerInd Groundwater Plus Infiltration in Structures

Total Predeveloped Recharge During Simulation	
Model Element	Recharge Amount (ac-ft)

Subbasin: Predeveloped Area	286.232
Link: New Copy Lnk1	0.000

Total:	286.232

Total Post Developed Recharge During Simulation	
Model Element	Recharge Amount (ac-ft)

Subbasin: Area to Detention Va	30.251
Link: Detention Vault	0.000

Total:	30.251

Total Predevelopment Recharge is Greater than Post Developed Average Recharge Per Year, (Number of Years= 158)
Predeveloped: 1.812 ac-ft/year, Post Developed: 0.191 ac-ft/year

*******Water Quality Facility Data*******

-----**SCENARIO: PREDEVELOPED**

Number of Links: 1

***** Link: New Copy Lnk1 *****

Infiltration/Filtration Statistics-----
 Inflow Volume (ac-ft): 151.09
 Inflow Volume Including PPT-Evap (ac-ft): 151.09
 Total Runoff Infiltrated (ac-ft): 0.00, 0.00%
 Total Runoff Filtered (ac-ft): 0.00, 0.00%
 Primary Outflow To Downstream System (ac-ft): 151.09
 Secondary Outflow To Downstream System (ac-ft): 0.00
 Percent Treated (Infiltrated+Filtered)/Total Volume: 0.00%

-----**SCENARIO: POSTDEVELOPED**

Number of Links: 1

***** Link: Detention Vault

Basic Wet Pond Volume (91% Exceedance): 6919. cu-ft
Computed Large Wet Pond Volume, 1.5*Basic Volume: 10378. cu-ft

Infiltration/Filtration Statistics-----
Inflow Volume (ac-ft): 709.75
Inflow Volume Including PPT-Evap (ac-ft): 709.75
Total Runoff Infiltrated (ac-ft): 0.00, 0.00%
Total Runoff Filtered (ac-ft): 0.00, 0.00%
Primary Outflow To Downstream System (ac-ft): 709.58
Secondary Outflow To Downstream System (ac-ft): 0.00
Percent Treated (Infiltrated+Filtered)/Total Volume: 0.00%

*******Compliance Point Results*******

Scenario Predeveloped Compliance Link: New Copy Lnk1
Scenario Postdeveloped Compliance Link: Detention Vault

***** Point of Compliance Flow Frequency Data *****
Recurrence Interval Computed Using Gringorten Plotting Position

Predevelopment Runoff		Postdevelopment Runoff	
Tr (Years)	Discharge (cfs)	Tr (Years)	Discharge (cfs)
2-Year	3.537E-02	2-Year	1.646E-02
5-Year	5.765E-02	5-Year	3.506E-02
10-Year	7.768E-02	10-Year	4.819E-02
25-Year	9.849E-02	25-Year	6.030E-02
50-Year	0.126	50-Year	7.686E-02
100-Year	0.136	100-Year	8.530E-02
200-Year	0.212	200-Year	8.543E-02
500-Year	0.314	500-Year	8.556E-02

** Record too Short to Compute Peak Discharge for These Recurrence Intervals

****** Flow Duration Performance ******

Excursion at Predeveloped 50%Q2 (Must be Less Than or Equal to 0%):	-26.5%	PASS
Maximum Excursion from 50%Q2 to Q2 (Must be Less Than or Equal to 0%):	-1.8%	PASS
Maximum Excursion from Q2 to Q50 (Must be less than 10%):	-1.4%	PASS
Percent Excursion from Q2 to Q50 (Must be less than 50%):	0.0%	PASS

MEETS ALL FLOW DURATION DESIGN CRITERIA: PASS

Appendix G

Conveyance Calculations

This page intentionally left blank.

Worksheet for Detention Discharge Pipe

Project Description

Friction Method	Manning Formula
Solve For	Discharge

Input Data

Roughness Coefficient	0.010	
Channel Slope	0.02000	ft/ft
Normal Depth	1.00	ft
Diameter	1.00	ft

Results

Discharge	6.55	ft³/s
Flow Area	0.79	ft ²
Wetted Perimeter	3.14	ft
Hydraulic Radius	0.25	ft
Top Width	0.00	ft
Critical Depth	0.97	ft
Percent Full	100.0	%
Critical Slope	0.01756	ft/ft
Velocity	8.34	ft/s
Velocity Head	1.08	ft
Specific Energy	2.08	ft
Froude Number	0.00	
Maximum Discharge	7.05	ft ³ /s
Discharge Full	6.55	ft ³ /s
Slope Full	0.02000	ft/ft
Flow Type	SubCritical	

GVF Input Data

Downstream Depth	0.00	ft
Length	0.00	ft
Number Of Steps	0	

GVF Output Data

Upstream Depth	0.00	ft
Profile Description		
Profile Headloss	0.00	ft
Average End Depth Over Rise	0.00	%
Normal Depth Over Rise	100.00	%
Downstream Velocity	Infinity	ft/s

Worksheet for Detention Discharge Pipe

GVF Output Data

Upstream Velocity	Infinity	ft/s
Normal Depth	1.00	ft
Critical Depth	0.97	ft
Channel Slope	0.02000	ft/ft
Critical Slope	0.01756	ft/ft

Appendix H

Operations and Maintenance Manual

This page intentionally left blank.

**Table V-4.5.2(3) Maintenance Standards - Closed Detention Systems
(Tanks/Vaults)**

Maintenance Component	Defect	Conditions When Maintenance is Needed	Results Expected When Maintenance is Performed
Storage Area	Plugged Air Vents	One-half of the cross section of a vent is blocked at any point or the vent is damaged.	Vents open and functioning.
	Debris and Sediment	Accumulated sediment depth exceeds 10% of the diameter of the storage area for 1/2 length of storage vault or any point depth exceeds 15% of diameter. (Example: 72-inch storage tank would require cleaning when sediment reaches depth of 7 inches for more than 1/2 length of tank.)	All sediment and debris removed from storage area.
	Joints Between Tank/Pipe Section	Any openings or voids allowing material to be transported into facility. (Will require engineering analysis to determine structural stability).	All joint between tank/pipe sections are sealed.
	Tank Pipe Bent Out of Shape	Any part of tank/pipe is bent out of shape more than 10% of its design shape. (Review required by engineer to determine structural stability).	Tank/pipe repaired or replaced to design.
	Vault Structure Includes Cracks in Wall, Bottom, Damage to Frame and/or Top Slab	Cracks wider than 1/2-inch and any evidence of soil particles entering the structure through the cracks, or maintenance/inspection personnel determines that the vault is not structurally sound. Cracks wider than 1/2-inch at the joint of any inlet/outlet pipe or any evidence of soil particles entering the vault through the walls.	Vault replaced or repaired to design specifications and is structurally sound. No cracks more than 1/4-inch wide at the joint of the inlet/outlet pipe.
Manhole	Cover Not in Place	Cover is missing or only partially in place. Any open manhole requires maintenance.	Manhole is closed.

**Table V-4.5.2(3) Maintenance Standards - Closed Detention Systems
(Tanks/Vaults) (continued)**

Maintenance Component	Defect	Conditions When Maintenance is Needed	Results Expected When Maintenance is Performed
	Locking Mechanism Not Working	Mechanism cannot be opened by one maintenance person with proper tools. Bolts into frame have less than 1/2 inch of thread (may not apply to self-locking lids).	Mechanism opens with proper tools.
	Cover Difficult to Remove	One maintenance person cannot remove lid after applying normal lifting pressure. Intent is to keep cover from sealing off access to maintenance.	Cover can be removed and reinstalled by one maintenance person.
	Ladder Rungs Unsafe	Ladder is unsafe due to missing rungs, misalignment, not securely attached to structure wall, rust, or cracks.	Ladder meets design standards. Allows maintenance person safe access.
Catch Basins	See "Catch Basins" (No. 5)	See "Catch Basins" (No. 5).	See "Catch Basins" (No. 5).

Table V-4.5.2(4) Maintenance Standards - Control Structure/Flow Restrictor

Maintenance Component	Defect	Condition When Maintenance is Needed	Results Expected When Maintenance is Performed
General	Trash and Debris (Includes Sediment)	Material exceeds 25% of sump depth or 1 foot below orifice plate.	Control structure orifice is not blocked. All trash and debris removed.
	Structural Damage	Structure is not securely attached to manhole wall. Structure is not in upright position (allow up to 10% from plumb). Connections to outlet pipe	Structure securely attached to wall and outlet pipe. Structure in correct position. Connections to outlet pipe are water tight; structure repaired or replaced and works as

Table V-4.5.2(4) Maintenance Standards - Control Structure/Flow Restrictor (continued)

Maintenance Component	Defect	Condition When Maintenance is Needed	Results Expected When Maintenance is Performed
		are not watertight and show signs of rust. Any holes - other than designed holes - in the structure.	designed. Structure has no holes other than designed holes.
Cleanout Gate	Damaged or Missing	Cleanout gate is not watertight or is missing. Gate cannot be moved up and down by one maintenance person. Chain/rod leading to gate is missing or damaged. Gate is rusted over 50% of its surface area.	Gate is watertight and works as designed. Gate moves up and down easily and is watertight. Chain is in place and works as designed. Gate is repaired or replaced to meet design standards.
Orifice Plate	Damaged or Missing	Control device is not working properly due to missing, out of place, or bent orifice plate.	Plate is in place and works as designed.
	Obstructions	Any trash, debris, sediment, or vegetation blocking the plate.	Plate is free of all obstructions and works as designed.
Overflow Pipe	Obstructions	Any trash or debris blocking (or having the potential of blocking) the overflow pipe.	Pipe is free of all obstructions and works as designed.
Manhole	See "Closed Detention Systems" (No. 3).	See "Closed Detention Systems" (No. 3).	See "Closed Detention Systems" (No. 3).
Catch Basin	See "Catch Basins" (No. 5).	See "Catch Basins" (No. 5).	See "Catch Basins" (No. 5).

Table V-4.5.2(5) Maintenance Standards - Catch Basins

Maintenance Component	Defect	Conditions When Maintenance is Needed	Results Expected When Maintenance is performed
General	Trash & Debris	<p>Trash or debris which is located immediately in front of the catch basin opening or is blocking inletting capacity of the basin by more than 10%.</p> <p>Trash or debris (in the basin) that exceeds 60 percent of the sump depth as measured from the bottom of basin to invert of the lowest pipe into or out of the basin, but in no case less than a minimum of six inches clearance from the debris surface to the invert of the lowest pipe.</p> <p>Trash or debris in any inlet or outlet pipe blocking more than 1/3 of its height.</p> <p>Dead animals or vegetation that could generate odors that could cause complaints or dangerous gases (e.g., methane).</p>	<p>No Trash or debris located immediately in front of catch basin or on grate opening.</p> <p>No trash or debris in the catch basin.</p> <p>Inlet and outlet pipes free of trash or debris.</p> <p>No dead animals or vegetation present within the catch basin.</p>
	Sediment	Sediment (in the basin) that exceeds 60 percent of the sump depth as measured from the bottom of basin to invert of the lowest pipe into or out of the basin, but in no case less than a minimum of 6 inches clearance from the sediment surface to the invert of the lowest pipe.	No sediment in the catch basin
	Structure Damage to Frame and/or Top Slab	Top slab has holes larger than 2 square inches or cracks wider than 1/4 inch. (Intent is to make sure no material is running into basin).	Top slab is free of holes and cracks. Frame is sit-

Table V-4.5.2(5) Maintenance Standards - Catch Basins (continued)

Maintenance Component	Defect	Conditions When Maintenance is Needed	Results Expected When Maintenance is performed
		Frame not sitting flush on top slab, i.e., separation of more than 3/4 inch of the frame from the top slab. Frame not securely attached	ting flush on the riser rings or top slab and firmly attached.
	Fractures or Cracks in Basin Walls/ Bottom	Maintenance person judges that structure is unsound. Grout fillet has separated or cracked wider than 1/2 inch and longer than 1 foot at the joint of any inlet/outlet pipe or any evidence of soil particles entering catch basin through cracks.	Basin replaced or repaired to design standards. Pipe is regouted and secure at basin wall.
	Settlement/ Misalignment	If failure of basin has created a safety, function, or design problem.	Basin replaced or repaired to design standards.
	Vegetation	Vegetation growing across and blocking more than 10% of the basin opening. Vegetation growing in inlet/outlet pipe joints that is more than six inches tall and less than six inches apart.	No vegetation blocking opening to basin. No vegetation or root growth present.
	Contamination and Pollution	See "Detention Ponds" (No. 1).	No pollution present.
Catch Basin Cover	Cover Not in Place	Cover is missing or only partially in place. Any open catch basin requires maintenance.	Catch basin cover is closed
	Locking Mechanism Not	Mechanism cannot be opened by one maintenance person with proper tools. Bolts into	Mechanism opens with

Table V-4.5.2(5) Maintenance Standards - Catch Basins (continued)

Maintenance Component	Defect	Conditions When Maintenance is Needed	Results Expected When Maintenance is performed
	Working	frame have less than 1/2 inch of thread.	proper tools.
	Cover Difficult to Remove	One maintenance person cannot remove lid after applying normal lifting pressure. (Intent is keep cover from sealing off access to maintenance.)	Cover can be removed by one maintenance person.
Ladder	Ladder Rungs Unsafe	Ladder is unsafe due to missing rungs, not securely attached to basin wall, misalignment, rust, cracks, or sharp edges.	Ladder meets design standards and allows maintenance person safe access.
Metal Grates (If Applicable)	Grate opening Unsafe	Grate with opening wider than 7/8 inch.	Grate opening meets design standards.
	Trash and Debris	Trash and debris that is blocking more than 20% of grate surface inletting capacity.	Grate free of trash and debris.
	Damaged or Missing.	Grate missing or broken member(s) of the grate.	Grate is in place and meets design standards.

Appendix I

CDM Smith Contaminated Soils Analysis

This page intentionally left blank.



14432 SE Eastgate Way, Suite 100
Bellevue, Washington 98007
tel: 425-519-8300
fax: 425-746-0197

June 7, 2018

Mr. William C. Hsu
Oseran Hahn P.S.
929 108th Avenue NE, Suite 1200
Bellevue, Washington 98004

Subject: Opinion of Probable Cost
Environmental Issues - King Property
2885 78th Avenue SE
Mercer Island, Washington

Dear Mr. Hsu:

This letter responds to your request for a second opinion regarding the probable cost to appropriately handle environmental conditions associated with the King Property located at 2885 78th SE. We understand that the Xing Hua Group. Ltd. a Washington Corporation is considering purchasing the property with the intention of demolishing the existing building and redeveloping it with a condominium complex. Over the past 6 years various due diligence studies (Phase 1 and 2 environmental site assessments [ESAs]) have been completed for the property. Recognized environmental conditions (RECs) identified during initial due diligence studies include the historical onsite dry cleaner and various offsite contamination sources (gas station sites, dry cleaners, etc.). Subsurface investigations have not identified impacts to the site from offsite sources. Relatively low concentrations of the dry cleaning chlorinated solvent tetrachloroethene (PCE) have been identified in soil and groundwater. These investigations also identified a single detection of oil-range total petroleum hydrocarbons (TPH-O) at a concentration exceeding the Model Toxics Control Act (MTCA) Method A cleanup level in the basecourse material underneath the asphalt. Based on these findings, Farallon Consulting (Farallon) developed two remediation cost estimates in 2014 and one currently, in 2018, which have varied greatly. In 2014 CDM Smith Inc. (CDM Smith) developed a remediation cost estimate at the request of the current owner, Mrs. Judy King. Our estimate was much lower than Farallon's.

The following presents a summary of the findings of due diligence studies completed to date and Farallon's remediation cost estimates. Using the information contained in these historical due diligence studies and any new information developed since 2014, we have re-evaluated and updated our 2014 remediation cost estimate.



Mr. William C. Hsu

June 7, 2018

Page 2

Site Description

The site is a 1.0-acre parcel of land. The property is tiered: the eastern portion is at an elevation of approximately 91 feet above mean sea level and the western portion at an elevation of approximately 81 feet above mean sea level. The property is developed with a 12,000-square-foot commercial building that is two stories in height on the east side and one story on the west side to account for the elevation variation. The first story tenant spaces on the lower tier are constructed as daylight basements. The remaining areas of the property consist of asphalt-paved parking with small landscaped areas. The building is currently occupied by a Chinese restaurant, insurance company, nail salon, and art gallery. A vacant space is also being used for temporary storage of garage sale items. For about 12 years, between approximately 2003 and 2015, one of the tenants in the lower level operated a dry cleaning business.

Past Environmental Investigations and Remediation Cost Estimates

The following summarizes environmental studies and/or remediation cost estimates completed by other consultants and CDM Smith. The documents reviewed by CDM Smith are referenced. The summary is organized by date, from oldest to most recent.

Pacific Crest Environmental

In June 2012, Pacific Crest Environmental completed a limited subsurface investigation to evaluate RECs identified during a Phase 1 ESA they had completed earlier.¹ These RECs included the presence of the onsite dry cleaner and potential onsite contamination from offsite sources, including the Shell-branded gas station across the street to the south, a reported release of petroleum hydrocarbons on the southeast adjoining property, nearby dry cleaners, and the fire station. Pacific Crest Environmental's investigation included drilling four borings at various locations on the property, collecting soil and groundwater samples from each boring, and submitting them for laboratory analysis. No analytes were detected except for 580 milligrams per kilogram (mg/kg) of TPH-O detected in a soil sample collected at a depth of 4-5 feet below ground surface (bgs). This concentration of TPH-O is less than the MTCA cleanup level, which is 2,000 mg/kg. Pacific Crest Environmental concluded that there had not been apparent impact from the RECs identified during the Phase 1 ESA on the subject property.

¹ Pacific Crest Environmental. 2012. Memorandum. Limited Subsurface Investigation, King Property 2885 78th Avenue SE, Mercer Island, Washington. Prepared for PMF Investments LLC. June 26.

Mr. William C. Hsu

June 7, 2018

Page 3

ABPB Consulting

In November 2012, ABPB Consulting completed a Phase 1 ESA and limited Phase 2 ESA for the property.² ABPB drilled and installed three monitoring wells on the south edge of the site to further evaluate the potential for petroleum contamination migration onto the subject property from the adjacent gas station to the south, as well as the presence of chlorinated solvents from onsite dry cleaning operations. All soil and groundwater samples collected and analyzed were non-detect for petroleum hydrocarbons and chlorinated volatile organic compounds (cVOCs). ABPB further concluded that the dry cleaning business “uses new sealed machines with spill protection and outside supply and waste removal services” and had “adequate controls and measures in place to prevent spills and cause contamination.”

Farallon

Farallon reported completing a Phase 1 ESA for the site in October 2013.³ They identified the same RECs as prior consultants had. In September 2013, Farallon conducted its first subsurface investigation (apparently these two investigations were conducted concurrently) which included: 1) sampling the four existing monitoring wells installed by others, 2) advancing 8 borings (5 onsite, and 3 on the adjacent parcel to the west) to collect soil and groundwater samples for analysis; and 3) collection and analysis of a soil gas sample adjacent to the dry cleaning machine.⁴

Trichloroethene (TCE) and *cis*-1,2-dichloroethene (*cis*-DCE) were detected at concentrations of 0.38 and 0.67 micrograms per liter ($\mu\text{g}/\text{L}$) in a groundwater sample collected from one boring. The concentrations of these compounds are less than their respective Method A/B groundwater cleanup levels by one to two orders of magnitude. No petroleum hydrocarbon or cVOC compounds were detected in any of the soil samples analyzed.

PCE was detected in the soil gas sample at a concentration of 2,000 micrograms per cubic meter ($\mu\text{g}/\text{m}^3$) and TCE was detected at a concentration of 5.2 $\mu\text{g}/\text{m}^3$. Farallon reported that the PCE and TCE concentrations in the soil gas sample exceed the MTCA Method B screening levels for soil gas in a residential setting, and that PCE exceeded its screening level in a commercial setting. It should be noted is that this is a very preliminary analysis, based on a single sub-slab sample collected next to an operating dry cleaning machine. This one sample is insufficient to make any conclusions regarding vapor intrusion.

² ABPB Consulting. 2012. Phase 1 Environmental Assessment and Limited Phase 2 Assessment. Mercer Island Multi-family Residential Site, 2885 78th Avenue SE, Mercer Island. Prepared for Continental Properties LLC. November 9.

³ Farallon Consulting. 2013. Summary of Subsurface Investigation, Mercer Island Apartments, 2885 78th Avenue Southeast, Mercer Island, Washington. Prepared for Hines Real Estate Investment Trust Properties. L.P. November 15.

⁴ Ibid.

Mr. William C. Hsu

June 7, 2018

Page 4

In December 2013, Farallon conducted additional investigation to further evaluate the potential for contamination associated with onsite dry cleaning operations.⁵ The results of this investigation are reported in a letter dated January 21, 2014 (Farallon, 2014). This second subsurface investigation consisted of extending four additional borings; three inside the dry cleaning unit and one inside the nail salon just east of the dry cleaning machine. PCE was detected in all three groundwater samples at concentrations ranging from 0.3 to 1.6 µg/L – all less than the Method A cleanup level of 5 µg/L. PCE was detected in soil samples at concentrations ranging between 0.011 to 0.051 mg/kg. One soil sample exceeded its Method A cleanup level of 0.05 mg/kg by 0.001 mg/kg (approximately 1 part per billion). This sample was collected within about a foot of the dry cleaning machine at a depth of 2.5 feet bgs. PCE concentrations in the three samples collected below this declined with depth. In one other sample, collected outside the building in the parking lot next to boring KP-3 where TPH-O was detected in soil, a sample collected at a depth of 0.5-foot bgs was reported to contain TPH-O at a concentration of 5,600 mg/kg, which exceeds the Method A cleanup level of 2,000 mg/kg. The TPH-O concentration at 4 ft bgs in this boring was only 81 mg/kg. There are a couple noteworthy considerations that CDM Smith identified regarding Farallon’s investigation of this area. First, in their boring logs, Farallon identified the surface material as concrete, which it is not. It is asphalt that is extensively cracked and degraded. The second is that Farallon collected a sample of what would be considered as basecourse material - not actual soil. Farallon’s sample collection is essentially equivalent to someone collecting a sample from a surficial area of oil staining commonly seen in any gravel parking lot – a condition considered de minimis.

In January 2014, Farallon also prepared a remediation cost estimate based on the results of their September and December 2013 investigations.⁶ Their estimate ranged between \$783,000 and \$1,637,000. In November 2014 Farallon submitted a revised remediation cost estimate. Their total cost estimated decreased significantly, reportedly because: (i) a vapor barrier was eliminated, as the buyer was “willing to bear the entire cost of this item;” and (ii) soil transport and disposal had been “dramatically reduced,” as “extensive testing helped shrink the box and our calculation methodology has been adjusted to include only the incremental cost difference between clean vs. contaminated soil.” It never has been clear to CDM Smith as to why a vapor barrier would be necessary. The buyer’s intention all along had been to conduct extensive soil excavation that would have removed the already very low concentrations of PCE in soil and groundwater. Besides which, Farallon never developed sufficient information to prove PCE concentrations in soil and

⁵ Farallon Consulting. 2014. Summary of Additional Subsurface Investigation, Mercer Island Apartments, 2885 78th Avenue Southeast, Mercer Island, Washington. Prepared for Hines Real Estate Investment Trust Properties. L.P. January 1.

⁶ Farallon Consulting. 2014. Preliminary Remedial Action Cost Estimate Ranges. Mercer Island Apartment Project, Mercer Island, Washington. Prepared for Hines Real Estate Investment Trust Properties. L.P. January.

Mr. William C. Hsu

June 7, 2018

Page 5

groundwater were high enough to create a hazard due to vapor intrusion. With the exception of 1 soil sample that exceeded the cleanup level by 0.001 mg/kg, Method A cleanup levels were not exceeded and Ecology generally considers that concentrations of contaminants less than Method A cleanup levels are protective with regard to vapor intrusion. It is also unclear as to Farallon's basis for "shrinking the box" of soil contamination when they had the same exact set of data as in their January 2014 estimate.

CDM Smith

In January 2014, CDM submitted an alternative cost estimate in response to Farallon's cost estimate.⁷ CDM Smith noted that this was not MTCA site because:

- There were no exceedances of MTCA cleanup levels in groundwater.
- The single PCE exceedance (0.001 mg/kg) is not significant. One could arguably use Ecology's criteria in this judgement which it easily passes. These criteria are: 1) no sample is greater than 2x the cleanup level; 2) less than 10% of the samples exceed the cleanup level; and 3) statistically the concentrations are less than the MTCA cleanup level.
- The data indicate that the oil-range TPH in soil is nothing more than surficial staining.

With the dry cleaner having vacated the property 3 years ago, it is possible that current testing next to the same boring where the single slight exceedance of PCE was detected in soil would show attenuation such that presently there is no MTCA exceedance in soil.

Based on this, CDM Smith's posited that the only issue was that soil impacted by PCE and TPH and excavated during redevelopment would need special handling during excavation and subsequent disposal in a landfill. For these reasons, CDM Smith eliminated various line items in Farallon's cost estimate. These included:

- Project costs to date: investigations conducted by the buyer are a cost of doing business and not considered recoverable.
- Cost recovery: it was unclear as to why this line item was a part of the remediation cost estimate.
- Additional characterization: The site has been sufficiently characterized.

⁷ CDM Smith. 2014. Evaluation of Farallon Consulting's Preliminary Remedial Action Cost Estimate Ranges, King Enterprises – Mercer Island Property. January.

Mr. William C. Hsu

June 7, 2018

Page 6

- Construction dewatering: The concentrations of PCE in groundwater are so low that they will be of no concern to King County (who own and operate the sewer system). In addition, by the time that water goes through any necessary treatment that is standard for any construction dewatering project (e.g., removal of suspended solids) and as it is mixed with water being pulled from other areas of the site, it is highly unlikely that PCE will even be present at concentrations greater than analytical method detection limits.
- Design of a soil vapor barrier: This is unjustified as PCE concentrations are already so low as not be an issue, and virtually, if not all, soil containing low concentrations of PCE will have been removed is unjustified.
- Ecology 5-year review: 5-year reviews are for sites with contamination remaining onsite which needs to be monitored, which is not a consideration at this site, as any potential contamination will have been removed.
- Long-term monitoring: There is nothing that would require long-term monitoring.

CDM Smith's estimated cost to deal with PCE and TPH-impacted soil was \$150,000.

Farallon's Current Environmental Investigations and Remediation Cost Estimate

In May 2018 Farallon conducted another Phase 1 ESA for the property.⁸ In addition, they purged and sampled two of the existing monitoring wells onsite; MW3 and MW5. MW3 is downgradient of the former dry cleaning facility. MW-5 is an angle boring that extends underneath the former dry cleaning machine. Concentrations of PCE and its degradation products were all less their method reporting limits in both samples, which was consistent with historical data. Farallon concluded that the historical dry cleaning operations were a REC, as well as the potential release of "hazardous substances" in connection with the historical oil burner with a possible heating oil underground storage tank (UST) on the site (note: heating oil is not technically a hazardous substance). In their report they stated that the "confirmed release of ORO (oil-range TPH) on the southwestern portion of the Site, may be related to the historical presence of this oil burner." This is highly speculative, considering that the sample Farallon is referring to was collected at 0.5-foot below ground surface in the basecourse material below very cracked asphalt. Farallon did not provide sufficient information to identify where this house had been located onsite, which could have been identified from aerial photographs. It is impossible to say whether the UST, if one existed, had been removed as a result of the redevelopment. However, in our experience, contamination associated with home

⁸ Farallon Consulting. 2018. Phase 1 Environmental Site Assessment Report, 2885 78th Avenue Southeast, Mercer Island, Washington. Prepared for Xing Hua Group. Ltd. a Washington Corporation. May 23.



Mr. William C. Hsu

June 7, 2018

Page 7

heating oil USTs, if any, is generally limited, especially in this case where the tank would have only been used for a period about 12 years.

In May 2018, Farallon also provided another remediation cost estimate.⁹ This estimate was formatted similar to their prior estimates but came in at \$800,100. The basis for most of the cost differential is the deeper planned excavation, all of which Farallon expects is contaminated.

Evaluation of Farallon's Current Remediation Cost Estimate

In CDM Smith's opinion, Farallon's \$800,100 estimate is grossly overestimated. The attached table provides a summary of Farallon's November 2014 and May 2018 estimates and CDM Smith's corresponding current estimate. For each line item we have provided a summary of the bases for our differences. The reasoning for some of our greatest differences are detailed further below:

- 1) The cost for soil disposal is overestimated. Farallon estimates that the cost to dispose of CID soil is \$83/ton and for TPH soil it is \$60/ton. We contacted Republic Services on June 5, 2018 to obtain current soil disposal costs. For contained-in-determination (CID) soils (i.e., PCE-impacted) the cost is \$50/ton, plus a 3.6% refuse tax. The cost for TPH soil is \$48/ton and there is no refuse tax. Trucking runs at \$165/hour. We estimate an hour to transport a minimum 25-ton load of soils to/from the transfer station in Seattle. We were further informed that Ecology no longer requires liners for CID soils, if they are transported in rail containers. This is a significant cost savings. Therefore, the base cost for CID soil would be about \$60/ton and \$55/ton for disposal of TPH soils. Adding a 20% markup for the contractor and 10% taxes brings these costs to about \$78 and \$72/ton, respectively.
- 2) Farallon's estimated contaminated soil volume is very high. Farallon makes some inaccurate assumptions. They assume that a minor PCE detection in water(B-20) will lead to additional CID soil even when they have 5 soil samples in the same boring that show PCE is not detected in soil. At another location (B-21) they assume excavation of CID to 30 feet bgs, even though PCE was only detected in the 2-ft (or less) sample. Their excavation limits essentially extend all the way to borings around the outside edges of the building where soil data indicates that CID soil was practically limited to under the dry cleaner unit itself, except for one 1-ft sample under the adjacent unit on the west and under the bathrooms behind the machine on the east. In our opinion, the actual volume of soil that may require landfill disposal is closer to 1,900 tons (1,800 tons CID, 100 tons TPH). We have increased the original volume estimate slightly to account for additional depth of excavation.

⁹ Farallon Consulting. 2018. Preliminary Remedial Action Cost Estimate Ranges. Mercer Island Apartment Project, Mercer Island, Washington. Prepared for Xing Hua Group. Ltd. a Washington Corporation.



Mr. William C. Hsu

June 7, 2018

Page 8

- 3) Farallon still includes unnecessary line items in their cost estimate. The PCE concentrations in groundwater are well below King County's sewer discharge limitations so treatment of groundwater, specifically for PCE during dewatering, will not be required prior to discharge to sewer. Also, there is no need for a 5-year review as there really never was no MTCA exceedances to speak of and what little impacted soil and groundwater there was will have been removed.

In conclusion, it is our opinion that a more reasonable estimate of the cost to handle and dispose of PCE and petroleum hydrocarbon-impacted soil identified on the site is on the order of \$205,600. Please note that for this level of estimate and based on how this material is handled and segregated during the excavation, the actual cost may be 30 percent lower or 50% higher due to uncertainties.

We appreciate the opportunity to provide consulting services for you. If you have any questions feel free to call us at (425) 519-8300.

Sincerely,

A handwritten signature in blue ink that reads "Pamela J. Morrill".

Pamela J. Morrill, LHG
Project Manager
CDM Smith Inc.

A handwritten signature in blue ink that reads "Matthew Schultz".

Matthew Schultz, P.E.
Principal
CDM Smith, Inc.

Attachment



Evaluation of of Farallon Consulting's Preliminary Remedial Action Cost Estimates
King Enterprises Mercer Island Property
June 6, 2018

Item #	Farallon Remedial Action Task	CDM Smith Comments/Evaluation	Farallon Cost Estimate (11/6/2014)	Farallon Cost Estimate (05/2018)	CDM Smith Cost Estimate (06/2018)
1)	Project Management	Project management for oversight/submittal of CID paperwork. No 5-yr review.	\$35,000	\$20,000	\$15,000
2)	Interaction with Regulatory Agencies	The only regulatory interaction needed is the contained-in determination (CID) request.	\$15,000	\$10,000	\$1,000
4)	EMMP	This could be completed in a week. It does not have to be approved by Ecology.	\$20,000	\$15,000	\$7,000
5)	Soil Transport and Disposal	Farallon's estimated soil volume is very high. Farallon makes some inaccurate assumptions. They assume that a minor PCE detection in water(B-20) will lead to additional CID soil even when they have 5 soil samples in the same boring that show PCE is not detected in soil. At another location (B-21) they assume excavation of CID soil to 30 feet bgs, even though PCE was only detected in the 2ft (or less) sample. Their excavation limits essentially extend all the way to borings around the outside edges of the building where soil data indicates that CID soil was practically limited to under the dry cleaner unit itself, except for one 1-ft sample under the adjacent unit on the west and under the bathrooms behind the machine on the east. In our opinion, the actual volume of soil that will require landfill disposal is closer to 1,900 tons (1,800 CID, 100 TPH). See text of letter for development of estimated disposal costs, which are \$72/ton for TPH soils and \$78/ton for CID soils.	\$226,000	\$530,100	\$147,600
6)	Construction Dewatering/Stormwater Treatment	Treating groundwater during construction dewatering with granulated activated carbon is unnecessary. Metro will accept water with these PCE concentration for disposal without treatment.	\$80,000	\$150,000	\$0
8)	Observation and Sampling	Estimated 12 days of oversight at \$1500/day, 30 samples at \$185/sample.	\$50,000	\$50,000	\$25,000
9)	Closure Report	The report of this nature is not complicated and just needs to document the methods, findings, and disposal methods. Only documentation required to go to Ecology is the soil disposal under the	\$25,000	\$20,000	\$10,000
10)	Ecology 5 year review	Not a MTCA site. Nothing left to do a 5 yr review on.	\$2,500	\$5,000	\$0
		Total Estimates	\$453,500	\$800,100	\$205,600